

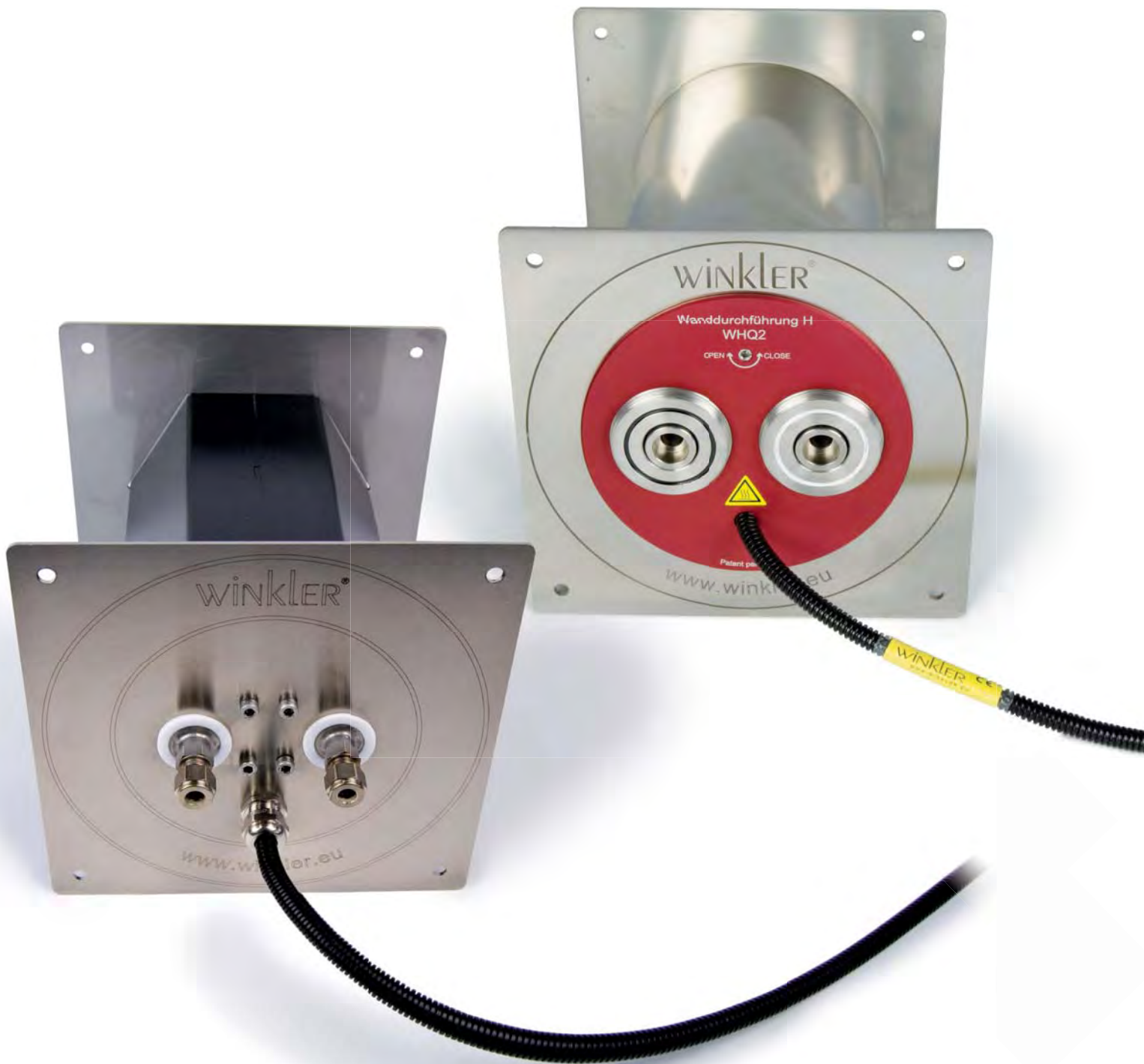

winkler



HEATED WALL BUSHINGS FOR ENGINE AND DYNAMOMETER TEST BENCHES



2010-06

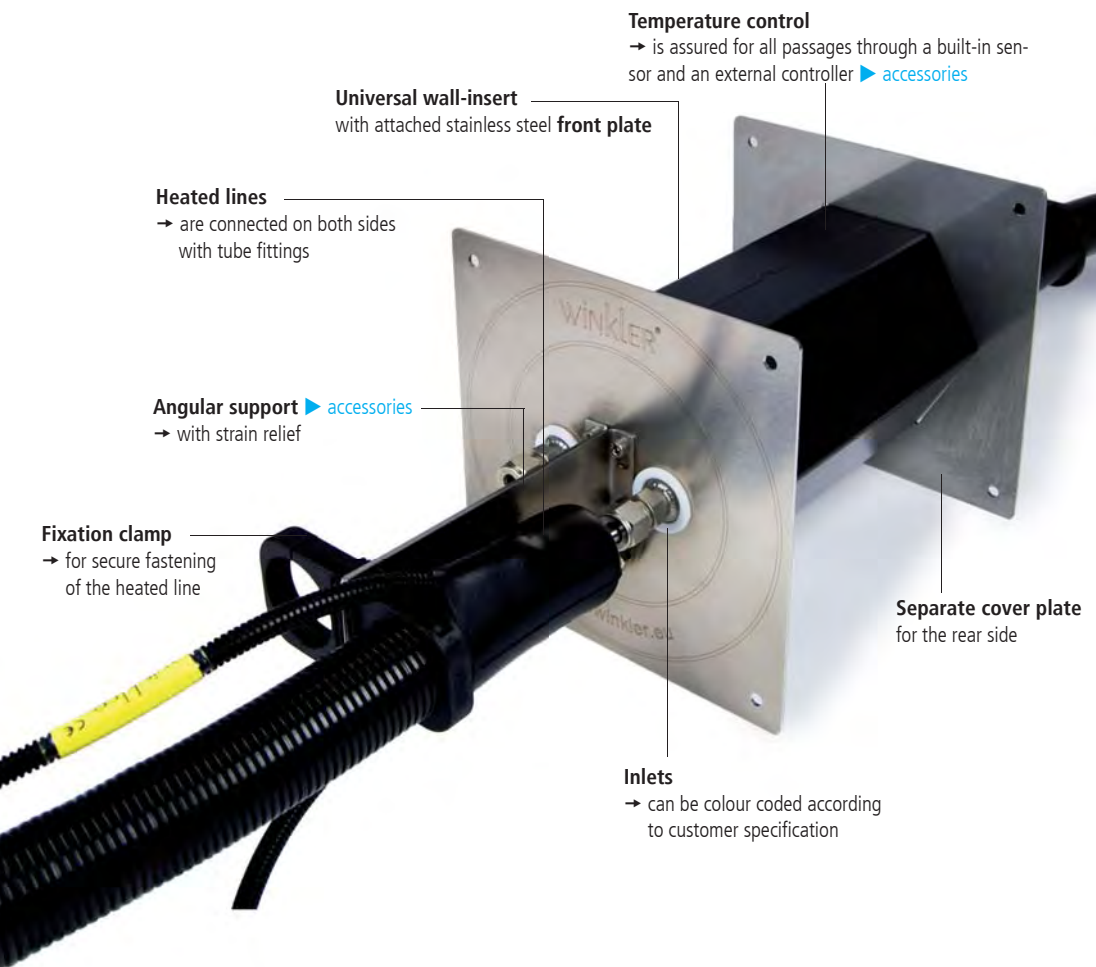

Easy installation:



1. Installation of the wall-insert in the wall



2. Opening of the fixation clamp



3. Insertion and connection of the heated lines



4. Installation of the insulation sleeve

Applications

On engine test beds or roller dynamometer test beds to channel measuring gases to the analyzer-room securely and according to norms.

Benefits

- Rugged design made of high-quality materials. The system is engineered for permanent operating temperatures up to 250°C.
- Due to the design, dimensional or angular variations of the wall are compensated without compromising function.
- Very efficient heating and very good insulation → low power consumption of 50 W/passage (at 250 mm length).
- Delivery fully-fledged including insulation sleeves WAZX1027 and all required fixation elements ▶ accessories.

Models

- Nominal diameter (=inner diameter of the heated passages) standard DN 6 and 4, others upon request.
- Length L (corresponds to wall thickness): 250 and 300 mm or any other according to customer specification
- Operating voltage: standard 230 VAC, other operating voltages upon request
- Sensor: standard Pt 100 or thermocouples type K or type J, other sensors upon request.

Options and versions

- Versions with separately temperature-controlled heated passages.

TECHNICAL DATA SERIES WAWHS

Model	WAWHS	1-way + 2-ways heated
A: Width of plate		210 mm
B: Hole distance		180 mm
L: Length (= wall thickness)		250, 300 mm or acc. to customer specification
D: Diameter		146 mm
Core hole bore		150 - 170 mm



1-way heated **WAWHS1**

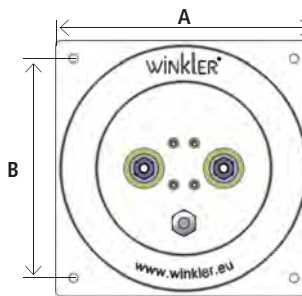

2-ways heated **WAWHS2**

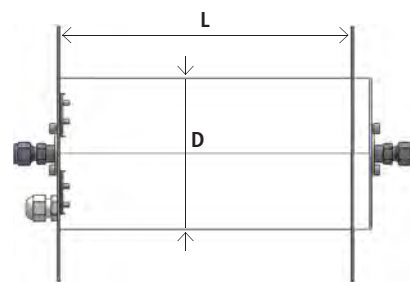

Model	WAWHS	3-ways + 4-ways heated
A: Width of plate		260 mm
B: Hole distance		230 mm
L: Length (= wall thickness)		250, 300 mm or acc. to customer specification
D: Diameter		196 mm
Core hole bore		200 - 220 mm



3-ways heated **WAWHS3**

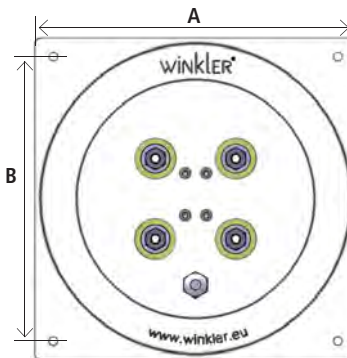

4-ways heated **WAWHS4**

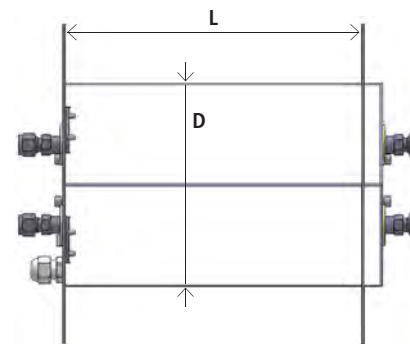

ACCESSORIES



Angular support complete with fixation clamps
Stainless steel 1.4301
Art.-Nr. **WAZX1026**



Fixation clamps
Art.-Nr. **WZXS3600**



Insulation sleeves with glas silk
Art.-Nr. **WAZX1027**



Temperature controller for wall installation
Art.-Nr. **WRW00110-230XP000**
(for sensor Pt 100)
Art.-Nr. **WRW00110-230XK000**
(for sensor type K)
Art.-Nr. **WRW00110-230XJ000**
(for sensor type J)

HEATED LINES WITH TUBE FITTINGS (detailed information in our catalogue „heated lines“)



Outside cover
(options see underneath)

Silicone cap

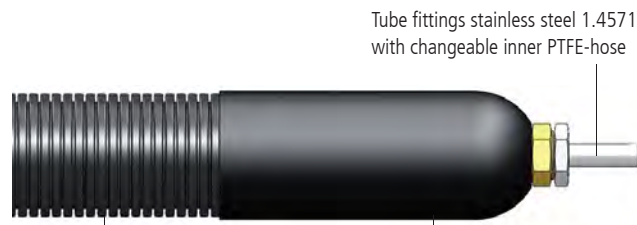

Outside cover
(options see underneath)

Silicone cap



G0 Polyamide (PA) braiding



G9 Stainless steel braiding



S2 Silicone skin



W2 Polyamide (PA) corrugated hose

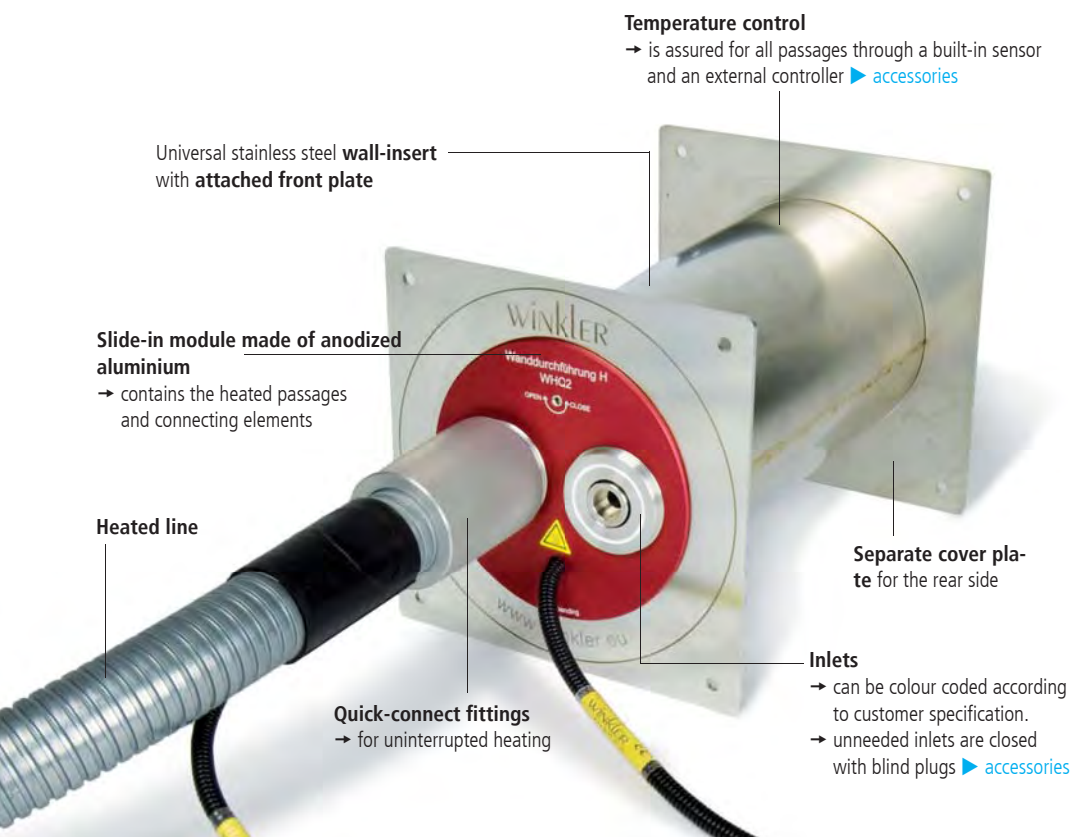

Easy installation:



1. Installation of the wall-insert in the wall



2. Insertion of the slide-in module



3. Locking with blind plug



4. Heated lines are connected and secured with the coupling nut

Applications

On engine test beds or roller dynamometer test beds to channel measuring gases to the analyzer-room securely and according to norms.

Benefits

- Rugged design made of high-quality materials. The system is engineered for permanent operating temperatures up to 200°C.
- Due to the design, dimensional or angular variations of the wall are compensated without compromising function.
- Easy maintenance and repair. A replacement of the slide-in module is easily and quickly done without having to open the wall-insert or damaging the wall.
- Very efficient heating and very good insulation → low power consumption of 50 W/passage (at 280 mm length).
- Continuous heating without cold spots (according to norm) between wall bushing and heated line.
- Delivery fully-fledged including insulating tape and all required fixation elements.

Models

- Nominal diameter (=inner diameter of the heated passages) standard DN 6 and 4, others upon request.
- Length L (corresponds to wall thickness): 200 mm, 240 mm and 280 mm or any other according to customer specification
- Operating voltage: standard 230 VAC, other operating voltages upon request
- Sensor: standard Pt 100, Pt1000 or thermocouples type K or type J, other sensors upon request.

Options and versions

- Versions with separately temperature-controlled heated passages.
- Versions for climate chambers with frost-free PVC rear cover plate.

ELECTRIC WALL BUSHINGS SERIES WAWEP

Applications and structure

- On engine test beds or roller dynamometer test beds to connect heated lines securely and according to norms.
- Basic design as with WHQ but without the heated passages and connecting elements. Plugs and sockets to connect heated lines are on built in on both sides and interconnected inside.

Options and versions

- Plugs and plug sockets according to customer specification
- Versions for climate chambers with heated slide-in module and frost-free PVC rear cover plate
- Combined wall bushings heated/electric
- Wall bushings for water, compressed air or other fluids according to customer specification.



TECHNICAL DATA SERIES WAWHQ AND WAWEP

Model	WAWHQ WAWEP	1-way + 2-ways heated 2-ways + 4-ways electric
A: Width of plate		210 mm
B: Hole distance		180 mm
L: Length (= wall thickness)		200, 240, 280 mm or acc. to customer specification
D: Diameter		146 mm
Core hole bore		150 - 170 mm



1-way heated **WAWHQ1**

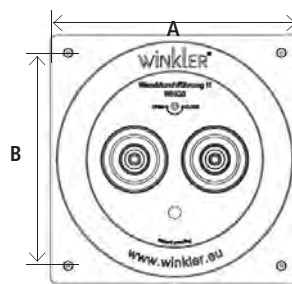

2-way heated **WAWHQ2**

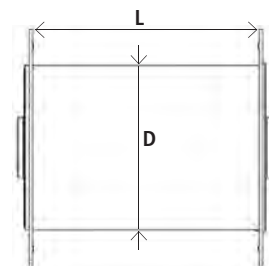

Model	WAWHQ	3-ways + 4-ways heated
A: Width of plate		260 mm
B: Hole distance		230 mm
L: Length (= wall thickness)		200, 240, 280 mm or acc. to customer specification
D: Diameter		196 mm
Core hole bore		200 - 220 mm

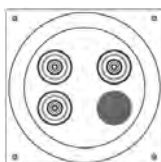

3-way heated **WAWHQ3**

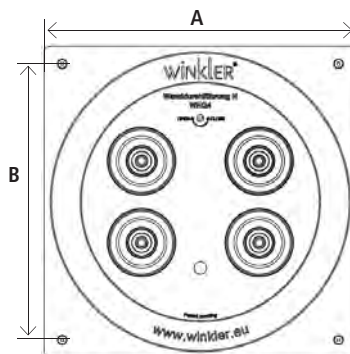

4-way heated **WAWHQ4**

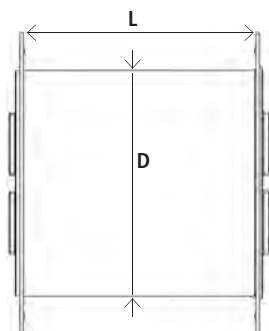

ACCESSORIES



Blind plug DN 6
Stainless steel 1.4305 with
Viton-seals
Art.-No. **WAZWBS06**



Blind plug support 2 x
Anodized aluminium
(incl. fixation elements,
without blind plugs)
Art.-No. **WAZWBSH2**



Blind plug support 4 x
Anodized aluminium
(incl. fixation elements,
without blind plugs)
Art.-No. **WAZWBSH4**



Temperature controller for wall installation
Art.-No. **WRW00110-230XP000** (for sensor Pt 100)
Art.-No. **WRW00110-230XK000** (for sensor type K)
Art.-No. **WRW00110-230XJ000** (for sensor type J)

HEATED LINES WITH QUICK-CONNECT FITTINGS (detailed information in our catalogue „heated lines“)

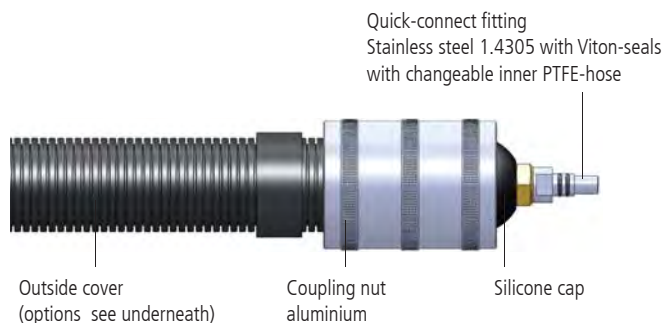
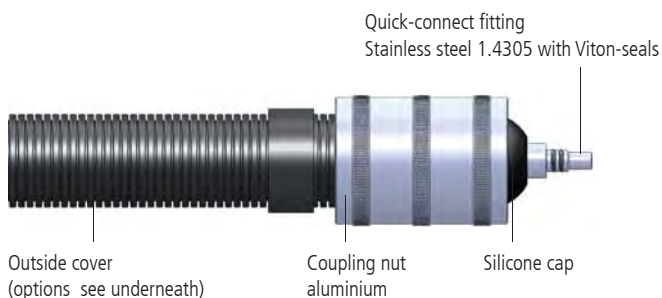

G0 Polyamide (PA) braiding



G9 Stainless steel braiding



S2 Silicone skin



W2 Polyamide (PA)
corrugated hose



W9 Stainless steel spiral hose

Temperature control

→ is assured for all passages through a built-in sensor and an external controller ▶ accessories

Universal wall-insert

with attached stainless steel front plate
→ contains the heated passages and connecting elements

Inlets with Quick-Lock

→ for safety mounting
→ unneeded inlets are closed with blind plugs ▶ accessories

Electric connections

→ for electric feed through

Separate cover plate for the rear side

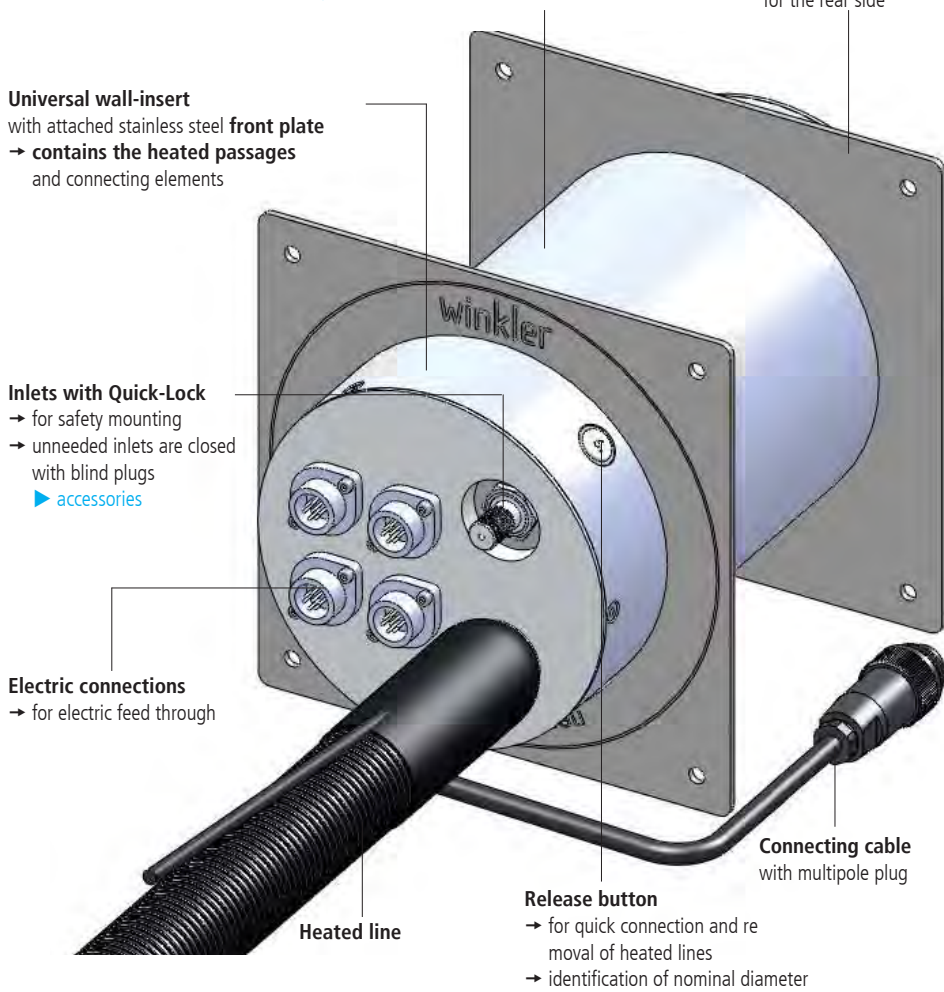

Easy installation:

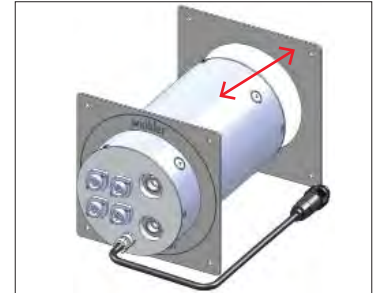

1. Remove rear cover plate



2. Installation of the wall-insert in the wall

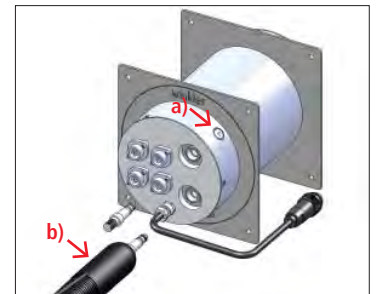

3. a) Press release button and
b) connect heated line



4. Unneeded inlets are closed with blind plugs

Applications

On engine test beds or roller dynamometer test beds to channel measuring gases to the analyzer-room securely and according to norms.

Benefits

- Rugged design made of high-quality materials. The system is engineered for permanent operating temperatures up to 250°C.
- Due to the design, dimensional or angular variations of the wall are compensated without compromising function.
- Easy maintenance and repair. A replacement of the slide-in module is easily and quickly done without having to open the wall-insert or damaging the wall.
- Very efficient heating and very good insulation → low power consumption of 50 W/passage (at 280 mm length).
- large variety of heated line models for the junction to the heated wall bushing
- quick and clean connection of heated lines

Models

- Nominal diameter (=inner diameter of the heated passages) standard DN 6 and 4, others upon request.
- Length L (corresponds to wall thickness): 200 mm, 250 mm and 300 mm (or any other according to customer specification) in addition to the overhang on both ends of 52 mm each
- Operating voltage: standard 230 VAC, other operating voltages upon request
- Sensor: standard Pt 100, Pt 1000 or thermocouples type K or type J, other sensors upon request.

Options and versions

- plugs and connectors according to customer specification
- wall bushings for water, compressed air and fluids according to customer specification upon request

TECHNICAL DATA SERIES WAWHQL

Model	WAWHQL	1-way + 2-ways heated
A: Width of plate	210 mm	
B: Hole distance	180 mm	
C1: Plate distance	49 mm	
C2: Wall distance	52 mm	
L: Length (= wall thickness)	200, 250, 300 mm or acc. to customer specification	
D: Diameter	154 mm	
Core hole bore	160 - 170 mm	



1-way heated WAWHQL

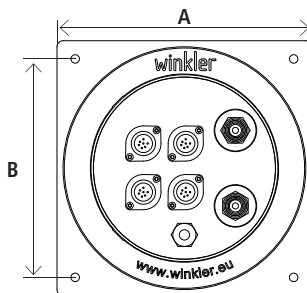

2-ways heated WAWHQL

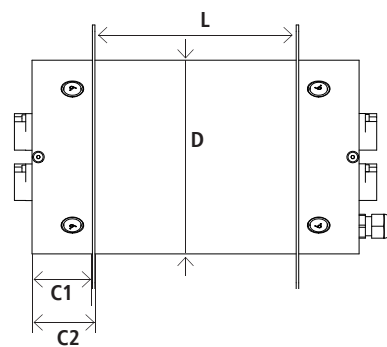

Model	WAWHQL	3-way + 3-ways heated
A: Width of plate	260 mm	
B: Hole distance	230 mm	
C1: Plate distance	49 mm	
C2: Wall distance	52 mm	
L: Length (= wall thickness)	200, 250, 300 mm or acc. to customer specification	
D: Diameter	204 mm	
Core hole bore	210 - 220 mm	

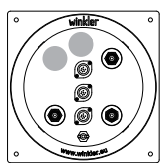

3-ways heated WAWHQL

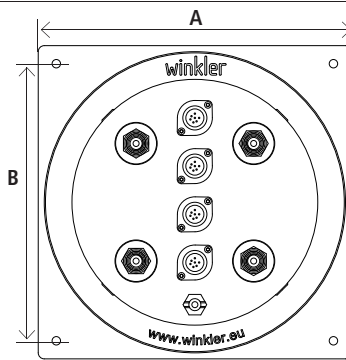

4-ways heated WAWHQL

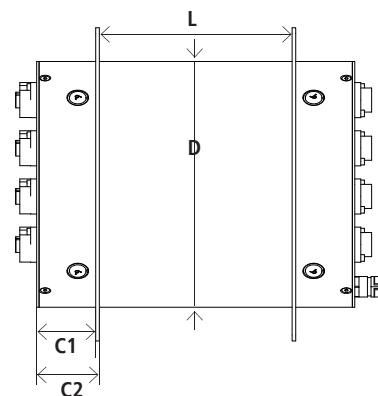

ACCESSORIES



Blind plug DN 6
Stainless steel 1.4305 with
Viton-seals
Art.-No. **WAZQLMBB**



Blind plug support 2 x
Anodized aluminium
(incl. fixation elements,
without blind plugs)

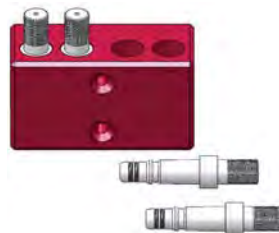

Blind plug support 4 x
Anodized aluminium
(incl. fixation elements,
without blind plugs)



Temperature controller for wall installation
Art.-No. **WRW00110-230XP000** (for sensor Pt 100)
Art.-No. **WRW00110-230XK000** (for sensor type K)
Art.-No. **WRW00110-230XJ000** (for sensor type J)

HEATED LINES WITH „QUICK-LOCK“ FITTINGS (detailed information in our catalogue „heated lines“)



G0 Polyamide (PA) braiding



G9 Stainless steel braiding



S2 Silicone skin



W2 Polyamide (PA)
corrugated hose



W9 Stainless steel spiral hose

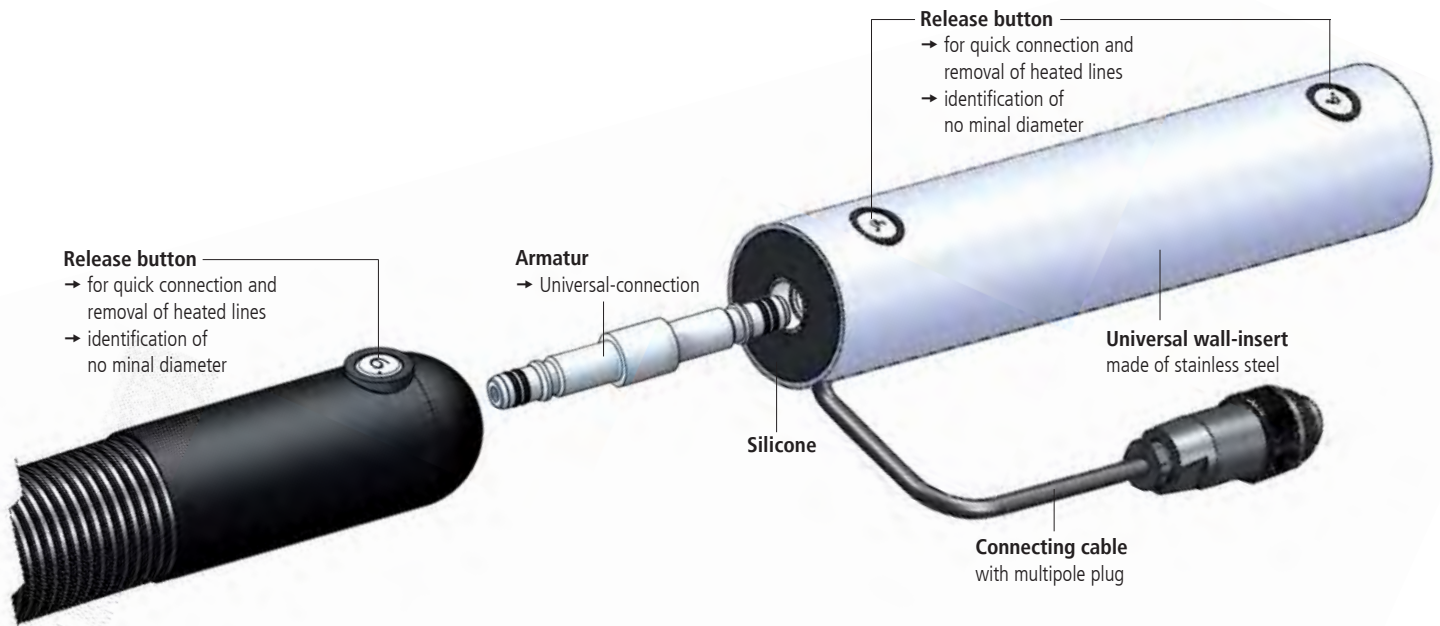

Applications

On engine test beds or roller dynamometer test beds to channel measuring gases to the analyzer-room securely and according to norms.

Benefits

- Rugged design made of high-quality materials. The system is engineered for permanent operating temperatures up to 200°C.
- Very efficient heating and very good insulation
- Continuous heating without cold spots (according to norm) between wall bushing and heated line.

Models

- Nominal diameter (=inner diameter of the heated passages) standard DN 6 and 4, others upon request.
- Length L (corresponds to wall thickness): 250 mm, 300 mm and 350 mm, or any other according to customer specification
- Operating voltage: standard 230 VAC, other operating voltages upon request
- Sensor: standard Pt 100, Pt 1000 or thermocouples type K or type J, other sensors upon request.

Technical data

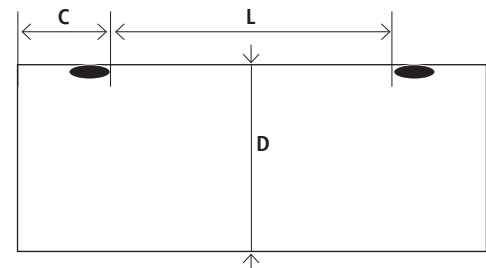

Model	WAWHQL
C: Distance release button	50 mm
L: Length (= wall thickness)	250, 300, 350 mm or acc. to customer specification
D: Diameter	54 mm
Core hole bore	60 mm

CONNECTION-SYSTEM „QUICK-LOCK“ FOR HEATED LINES

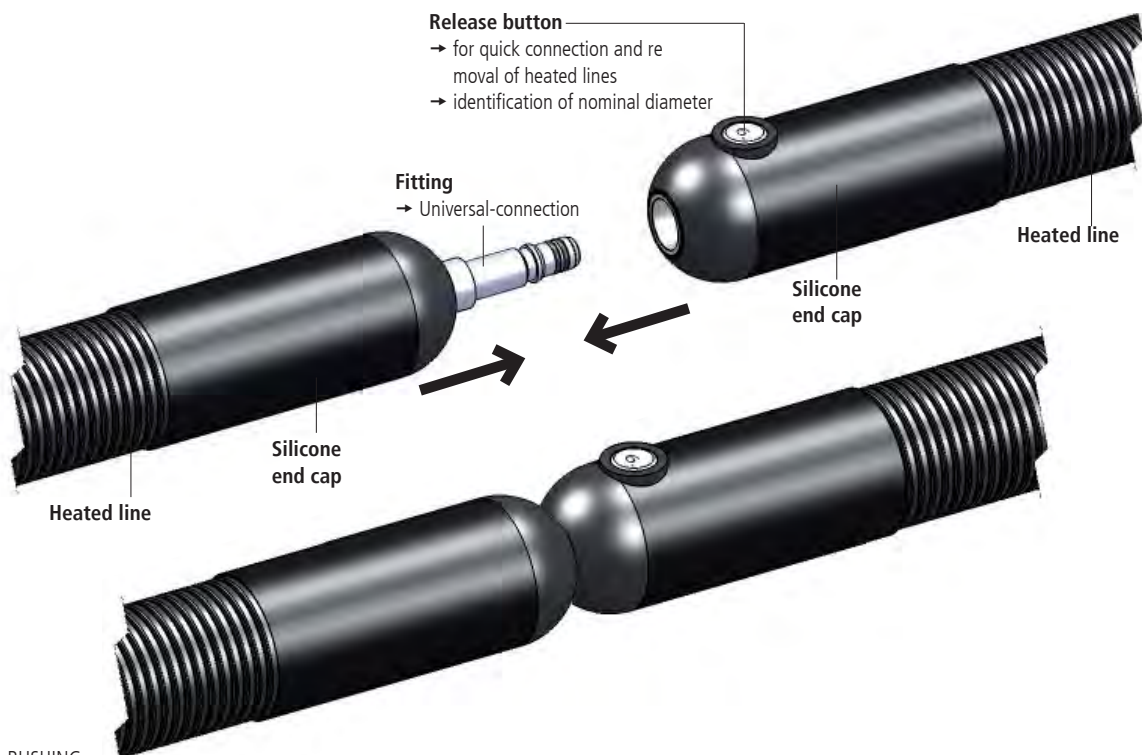

Winkler „Quick-Lock“ = connecting flexibility + gas tightness + continuous heating without cold spots!

Fitting „Quick-Lock“ male (type QLM)
available for heated lines in DN 4 and DN 6

Universal-connection QLM - QLM
to connect two heated lines
(compatible with DN 4 and DN 6)
Art.-n° **WAZQLMMB**



Fitting «Quick-Lock» female (type QLW)
available for heated lines in DN 4 and DN 6



Universal blind plug male
(compatible with DN 4 and DN 6)
Art.-n° **WAZQLMBB**



Universal blind plug female
(compatible with DN 4 and DN 6)
Art.-n° **WAZQLMBB**



Art.-n° **WAZQLMA4** (DN 4)
Fitting "quick-lock" male with screw thread for heated lines with interchangeable inner line



Art.-n° **WAZQLMA4** (DN 6)
Fitting "quick-lock" male with screw thread for heated lines with interchangeable inner line



Connection QLM - tube fitting **25 mm**
Art.-n° **WAZQLMRL-025VZ004** with OD 6 mm
Art.-n° **WAZQLMRL-025VZ006** with OD 8 mm

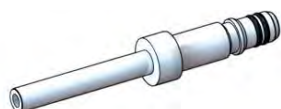

Connection QLM - tube fitting **50 mm**
Art.-n° **WAZQLMRL-050VZ004** with OD 6 mm
Art.-n° **WAZQLMRL-050VZ006** with OD 8 mm

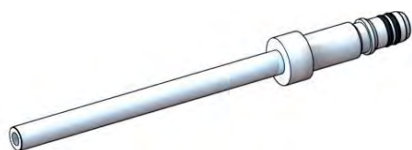

Connection QLM - tube fitting **100 mm**
Art.-n° **WAZQLMRL-100VZ004** with OD 6 mm
Art.-n° **WAZQLMRL-100VZ006** with OD 8 mm

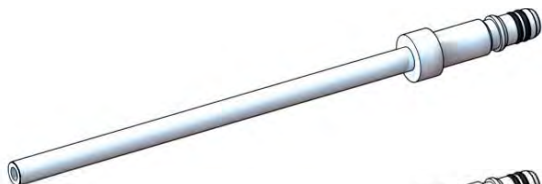

Connection QLM - tube fitting **150 mm**
Art.-n° **WAZQLMRL-150VZ004** with OD 6 mm
Art.-n° **WAZQLMRL-150VZ006** with OD 8 mm

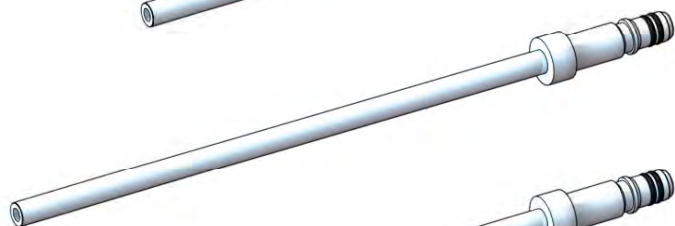

Connection QLM - tube fitting **200 mm**
Art.-n° **WAZQLMRL-200VZ004** with OD 6 mm
Art.-n° **WAZQLMRL-200VZ006** with OD 8 mm

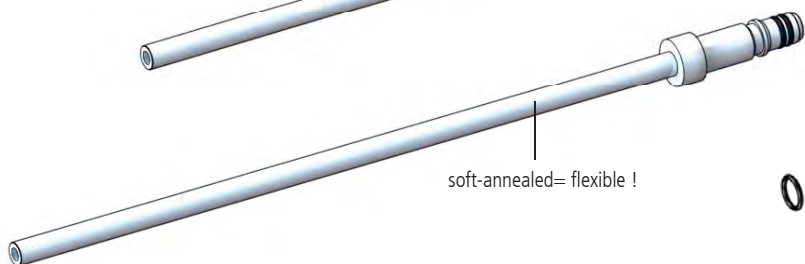

Connection QLM - tube inox **500 mm** (soft-annealed)
Art.-n° **WAZQLMRL-500VZ004** with OD 6 mm
Art.-n° **WAZQLMRL-500VZ006** with OD 8 mm

soft-annealed= flexible !



Spare seals (O-Ring) in Viton (10 pieces)
Art.-n° **WAZQVDRB**

Application with plug seal

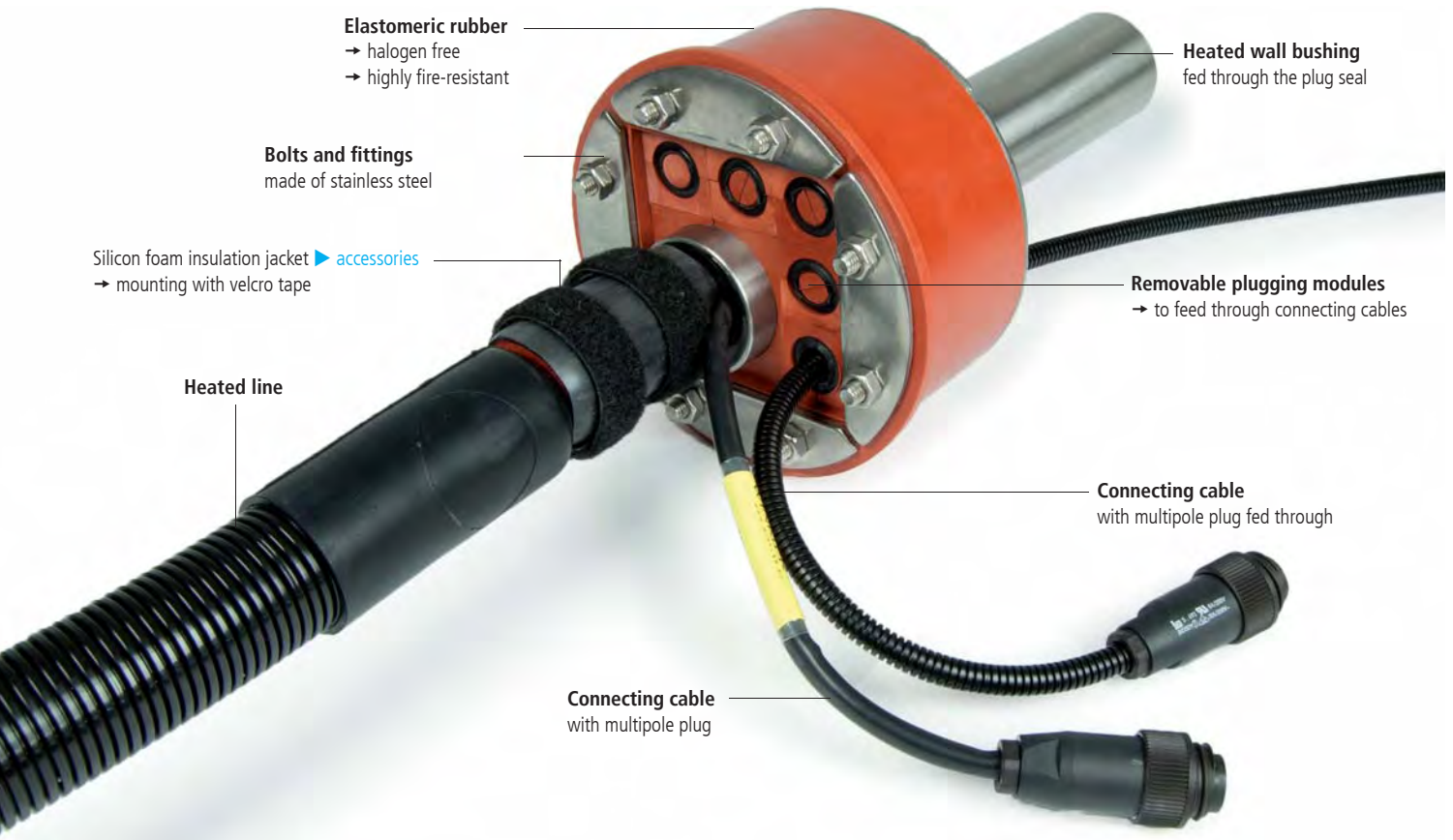

Applications

On engine test beds or roller dynamometer test beds to channel measuring gases to the analyzer-room securely and according to norms.

Benefits

- Rugged design made of high-quality materials.
- The system is engineered for permanent operating temperatures up to 200°C.
- Continuous heating without cold spots

Models

- Nominal diameter (=inner diameter of the heated passages) standard DN 4 and 6 others upon request.
- Length L (corresponds to wall thickness): 200 mm, 250 mm and 300 mm or any other according to customer specification
- Operating voltage: standard 230 VAC, other operating voltages upon request
- Sensor: standard Pt 100 or thermocouples type K or type J, other sensors upon request.

Technical Datas

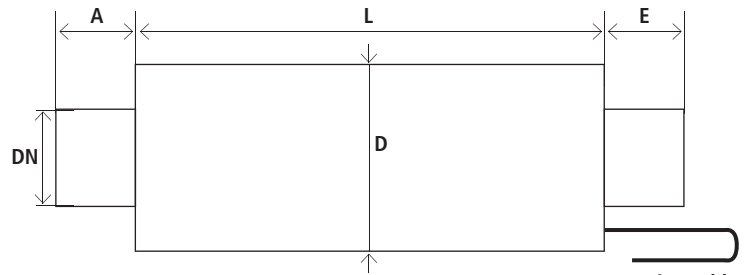

- A:** Overhang (A-side)
- E:** Overhang electric connection side (E-side)
- L:** Length (= wall thickness)
- DN:** Nominal diameter
- D:** Outer diameter

ACCESSORIES

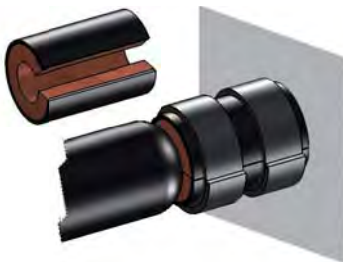

Insulation jacket
Art.-Nr. **WAZX102**



Temperature controller for wall installation
Art.-Nr. **WRW00110-230XP000** (for sensor Pt 100)
Art.-Nr. **WRW00110-230XK000** (for sensor type K)
Art.-Nr. **WRW00110-230XJ000** (for sensor type J)

Heated wall bushing made of stainless steel, sealed with silicone

	A: Overhang (A-side)	25 mm or acc. to customer specification
	E: Overhang electric connection side (E-side)	25 mm or acc. to customer specification
	L: Length (= wall thickness)	250, 300, 350 mm or acc. to customer specification
	DN: Nominal diameter	4 (6 x 1 mm); 6 (8 x 1 mm); 8 (10 x 1 mm); 10 (12 x 1 mm)
	D: Outer diameter	54 mm
	Core hole bore	60 mm
	A: Overhang (A-side)	100 mm or acc. to customer specification
	E: Overhang electric connection side (E-side)	100 mm or acc. to customer specification
	L: Length (= wall thickness)	or acc. to customer specification
	DN: Nominal diameter	80 (88,9 x 2 mm)
	D: Outer diameter	154 mm
	Core hole bore	160 mm
	A: Overhang (A-side)	100 mm or acc. to customer specification
	E: Overhang electric connection side (E-side)	100 mm or acc. to customer specification
	L: Length (= wall thickness)	or acc. to customer specification
	DN: Nominal diameter	150 (154 x 2 mm)
	D: Outer diameter	204 mm
	Core hole bore	210 mm
	A: Overhang (A-side)	100 mm or acc. to customer specification
	E: Overhang electric connection side (E-side)	100 mm or acc. to customer specification
	L: Length (= wall thickness)	or acc. to customer specification
	DN: Nominal diameter	200 (204 x 2 mm)
	D: Outer diameter	254 mm
	Core hole bore	260 mm

Winkler GmbH is an independent, medium-sized company located in Heidelberg (Germany). For more than 30 years we have been developing and manufacturing a broad range of electric heating solutions for industry and laboratory applications.

We supply reliable and durable products made of high-quality materials.

We are the right partner for innovative and quick answers to your requirements. Customized solutions and flexible manufacturing are our particular strengths. Our experienced specialists will offer you sound advice and - together with you - develop the heating solution tailored to your application.

Winkler - Your heating solution!



Our headquarter



Heidelberg

Winkler GmbH
Englerstrasse 24
D-69126 Heidelberg
Germany

Tel. +49-6221-3646-0
Fax +49-6221-3646-40
E-Mail sales@winkler.eu
www.winkler.eu



Our product range

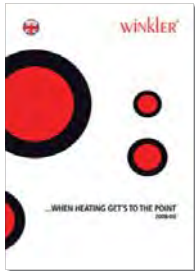

Company presentation



Heated lines & heated hoses



Atex Heated lines



Heated wall bushings



Heated hoses



Heated hoses for pharmaceutical, chemical and food applications



Heating jackets



Silicone heaters & heating foils



Laboratory heaters



Drum and IBC heaters



Heating Solutions for Rail Applications

Your contact:

Frank Mayer

Sales Manager for Heated Lines and Heated Hoses

Tel. +49-6221-3646-16

Fax: +49-6221-3646-40

E-Mail: motor@winkler.eu



Agencies

AUSTRIA

Ing. Wolfgang Stipanitz, A-4060 Leonding

Tel. +43-732-770177

Fax +43-732-770177-7

E-Mail: sales@winkler-austria.com

FRANCE

André Weinzaepflen, F-75016 Paris

Tel. +33-1-46041590

Fax +33-1-46041590

E-Mail: commercial@winkler-france.com

BENELUX

KSR H&H Measurement BV, NL-5133 NE Riel

Tel. +31-13-5339688

Fax +31-13-5331962

E-Mail: sales@winkler-benelux.com