

## Easy installation:



1. Installation of the wall-insert in the wall



2. Opening of the fixation clamp



3. Insertion and connection of the heated lines



4. Installation of the insulation sleeve

## Applications

On engine test beds or roller dynamometer test beds to channel measuring gases to the analyzer-room securely and according to norms.

## Benefits

- Rugged design made of high-quality materials. The system is engineered for permanent operating temperatures up to 250°C.
- Due to the design, dimensional or angular variations of the wall are compensated without compromising function.
- Very efficient heating and very good insulation → low power consumption of 50 W/passage (at 250 mm length).
- Delivery fully-fledged including insulation sleeves WAZX1027 and all required fixation elements ▶ accessories.

## Models

- Nominal diameter (=inner diameter of the heated passages) standard DN 6 and 4, others upon request.
- Length L (corresponds to wall thickness): 250 and 300 mm or any other according to customer specification
- Operating voltage: standard 230 VAC, other operating voltages upon request
- Sensor: standard Pt 100 or thermocouples type K or type J, other sensors upon request.

## Options and versions

- Versions with separately temperature-controlled heated passages.

## TECHNICAL DATA SERIES WAWHS

<b>Model</b>	<b>WAWHS</b>	1-way + 2-ways heated
<b>A:</b> Width of plate		210 mm
<b>B:</b> Hole distance		180 mm
<b>L:</b> Length (= wall thickness)		250, 300 mm or acc. to customer specification
<b>D:</b> Diameter		146 mm
Core hole bore		150 - 170 mm



1-way heated **WAWHS1**

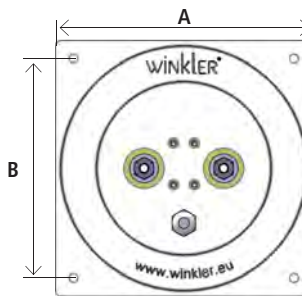

2-ways heated **WAWHS2**

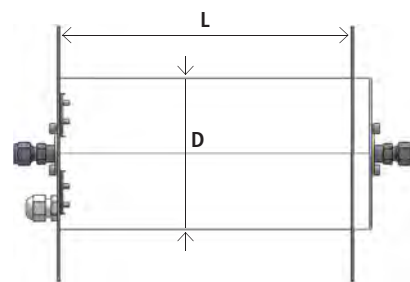

<b>Model</b>	<b>WAWHS</b>	3-ways + 4-ways heated
<b>A:</b> Width of plate		260 mm
<b>B:</b> Hole distance		230 mm
<b>L:</b> Length (= wall thickness)		250, 300 mm or acc. to customer specification
<b>D:</b> Diameter		196 mm
Core hole bore		200 - 220 mm



3-ways heated **WAWHS3**

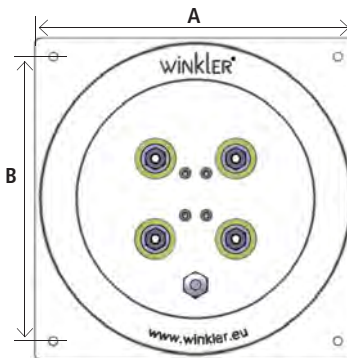

4-ways heated **WAWHS4**

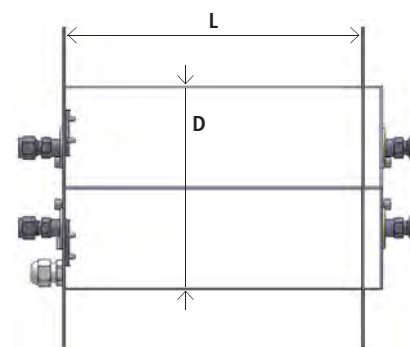

## ACCESSORIES



**Angular support complete with fixation clamps**  
Stainless steel 1.4301  
Art.-Nr. **WAZX1026**



**Fixation clamps**  
Art.-Nr. **WZXS3600**



**Insulation sleeves with glas silk**  
Art.-Nr. **WAZX1027**



**Temperature controller for wall installation**  
Art.-Nr. **WRW00110-230XP000**  
(for sensor Pt 100)  
Art.-Nr. **WRW00110-230XK000**  
(for sensor type K)  
Art.-Nr. **WRW00110-230XJ000**  
(for sensor type J)

## HEATED LINES WITH TUBE FITTINGS (detailed information in our catalogue „heated lines“)

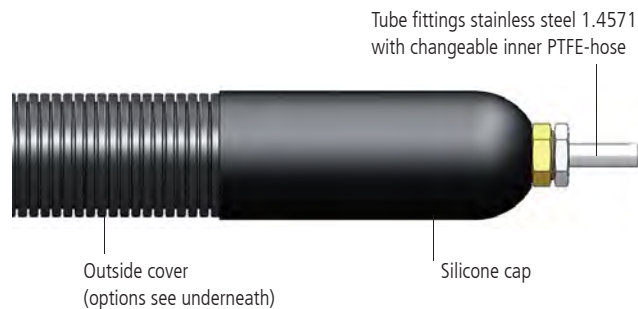
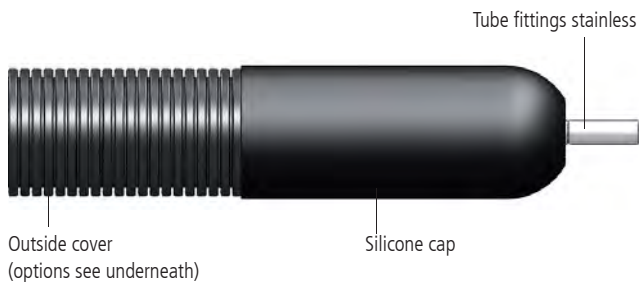

**G0** Polyamide (PA) braiding



**G9** Stainless steel braiding



**S2** Silicone skin



**W2** Polyamide (PA) corrugated hose