

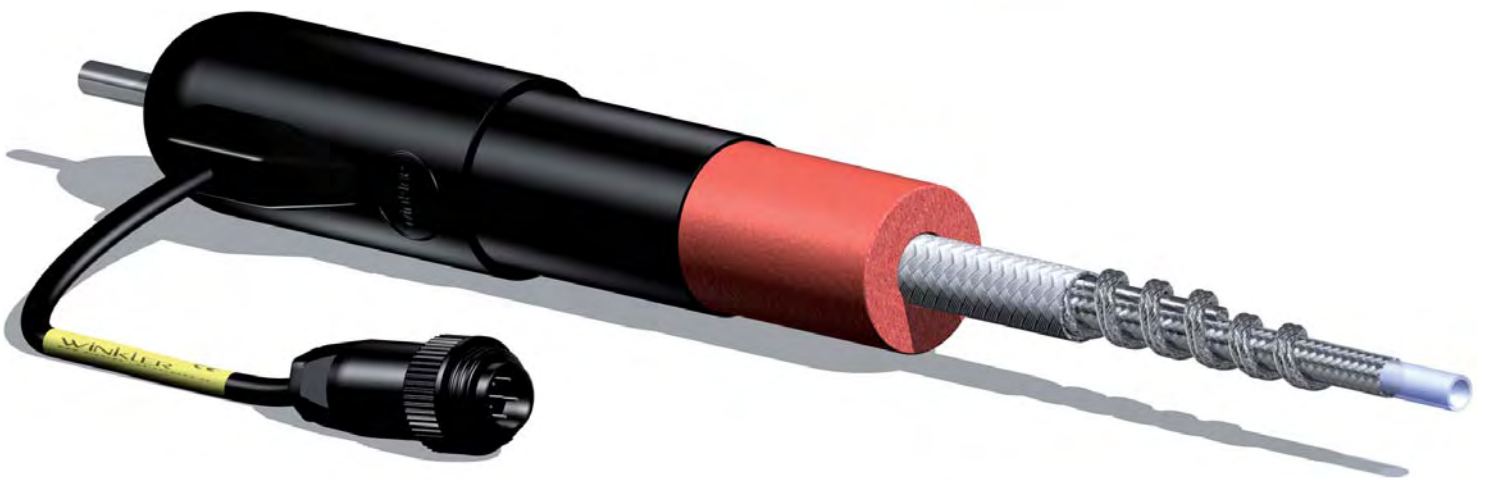

winkler®

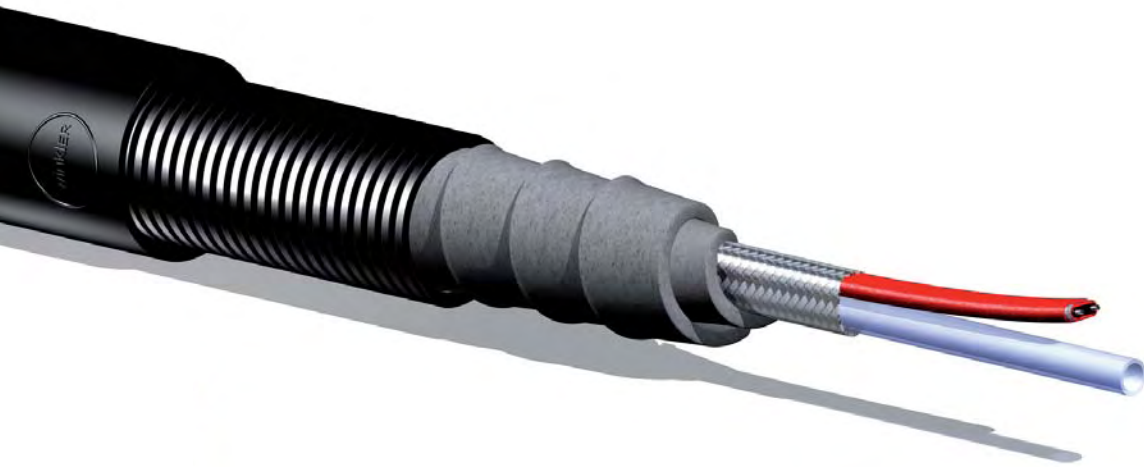

**HEATED LINES FOR THE ENVIRONMENTAL
MEASUREMENT AND FOR ENGINE AND
DYNAMOMETER TEST BENCHES
CATALOGUE 2009-04**



Codes for the outer cover

Protective braidings ▶Page 8

- G0** Black polyamide (PA) braiding
- G1** **G2** **G3** **G4**
PA braiding - red - orange - blue - grey
- G8** Galvanised steel braiding
- G9** Stainless steel braiding

Silicon covers ▶Page 8

- S0** Red silicon foam
- S1** Black silicon skin 30 mm
- S2** Black silicon skin 40 mm

Protective hoses ▶Page 10

- W2** Black PA corrugated hose
- W3** Black TPE corrugated hose
- W7** Black PUR corrugated hose
- W8** Galvanised steel spiral hose
- W9** Stainless steel spiral hose

Codes for the maximum operating temperature or power

Maximum operating temperature T_{Max} in °C
(Heated lines with heating cable)

10 = 100°C	30 = 300°C
20 = 200°C	35 = 350°C
25 = 250°C	40 = 400°C

Power in W/m ▶Page 4
(Heated lines with heating tape)

WAL	10 = 10 W/m
	15 = 15 W/m
	26 = 26 W/m

WAP	40 = 40 W/m
WAH	25 = 25 W/m
	45 = 45 W/m
	60 = 60 W/m

Codes for the basic hose and fittings ▶Page 14

- | | |
|---|--|
| 0 PTFE-hose | 5 Stainless steel tube |
| 1 Exchangeable PTFE hose in hose | 6 Exchangeable PTFE hose |
| 2 n. a. | 7 Stainless steel corrugated hose |
| 3 PTFE basic hose + tube ends | 8 Exchangeable PTFE hose + exchang. tube ends |
| 4 Exchangeable PTFE hose + tube ends | 9 Exchangeable PTFE hose + ferrule fittings |

W A K G 0 2 0 3 - 2 3 0 X P 0 0 6 - 1 5 0 0 S T N D

Type	Serial code	Configuration STND = Standard product												
	Special number													
WAL ▶Page 4-5 WAH ▶Page 4-5 WAP ▶Page 4-5 WEX ▶Page 6-7 WAKG ▶Page 8-9 WAKS ▶Page 8-9 WAKW ▶Page 10-11 WAF ▶Page 12 WAM ▶Page 13	Line length L (cm) ▶Page 15	Nominal diameter ND (mm) ▶Page 15												
	Sensor type ▶Page 16													
	<table border="1"> <tr><td>..P = Pt 100 (2 wire)</td><td>..B = Bimetal limiter</td></tr> <tr><td>..T = Pt 100 (3 wire)</td><td>..S = Thermal fuse</td></tr> <tr><td>..Q = Pt 100 (4 wire)</td><td>..C = Capillary sensor</td></tr> <tr><td>..E = Ex-Pt 100</td><td>..M = Multiple sensors</td></tr> <tr><td>..K = Thermocouple type K (NiCr-Ni)</td><td>..W = Selectable sensors</td></tr> <tr><td>..J = Thermocouple type J (Fe-CuNi)</td><td>PK = Pt 100+Thermocouple type K</td></tr> </table>	..P = Pt 100 (2 wire)	..B = Bimetal limiter	..T = Pt 100 (3 wire)	..S = Thermal fuse	..Q = Pt 100 (4 wire)	..C = Capillary sensor	..E = Ex-Pt 100	..M = Multiple sensors	..K = Thermocouple type K (NiCr-Ni)	..W = Selectable sensors	..J = Thermocouple type J (Fe-CuNi)	PK = Pt 100+Thermocouple type K	Sensor quantity ▶Page 16
	..P = Pt 100 (2 wire)	..B = Bimetal limiter												
	..T = Pt 100 (3 wire)	..S = Thermal fuse												
	..Q = Pt 100 (4 wire)	..C = Capillary sensor												
	..E = Ex-Pt 100	..M = Multiple sensors												
..K = Thermocouple type K (NiCr-Ni)	..W = Selectable sensors													
..J = Thermocouple type J (Fe-CuNi)	PK = Pt 100+Thermocouple type K													
<table border="1"> <tr><td>XX = No sensor</td><td>Z.. = Double sensor</td></tr> <tr><td>YY = Without sensor (is an option)</td><td>D.. = Triple sensor</td></tr> <tr><td>X.. = Single sensor</td><td>V.. = Quadruple sensor</td></tr> <tr><td></td><td>F.. = Quintuple sensor</td></tr> </table>	XX = No sensor	Z.. = Double sensor	YY = Without sensor (is an option)	D.. = Triple sensor	X.. = Single sensor	V.. = Quadruple sensor		F.. = Quintuple sensor						
XX = No sensor	Z.. = Double sensor													
YY = Without sensor (is an option)	D.. = Triple sensor													
X.. = Single sensor	V.. = Quadruple sensor													
	F.. = Quintuple sensor													
Operating voltage (V) ▶Page 16	<table border="1"> <tr><td>012 = 12 V</td><td>115 = 115 V</td></tr> <tr><td>024 = 24 V</td><td>230 = 230 V</td></tr> <tr><td>048 = 48 V</td><td>400 = 400 V</td></tr> <tr><td></td><td>1W2 = selectable 115 V / 230 V</td></tr> </table>		012 = 12 V	115 = 115 V	024 = 24 V	230 = 230 V	048 = 48 V	400 = 400 V		1W2 = selectable 115 V / 230 V				
012 = 12 V	115 = 115 V													
024 = 24 V	230 = 230 V													
048 = 48 V	400 = 400 V													
	1W2 = selectable 115 V / 230 V													

Note:
All the descriptions and illustrations of the products in this catalogue are non-binding and correspond to our current state of knowledge.

Winkler reserves the right to modify the products described here at any time and without prior notice if considered necessary for the purpose of further development or constructional reasons.

Winkler technology

With more than 25 years of experience, Winkler stands for reliable products and intelligent innovations in industrial heat engineering. We offer the broadest range of flexible heating systems, control & monitoring equipment and accessory products for exacting analytical measurement.

Heated lines from Winkler are used in analytical systems for monitoring air pollutants in power stations and waste incineration plants as well as for process analysis in industry. They serve to transport gas samples without falsification from the sampling point to the gas treatment system and analyser. Thanks to their high degree of durability, they can be in use for many years, often round the clock and under tough conditions. The whole bandwidth of heating solutions from Winkler is also demonstrated at engine test beds for the calibration and optimization of combustion engines in the context of further development as well as at chassis dynamometers for statutory emission testing and vehicle certification.

The accuracy and reproducibility with which sensors and instruments in analytical systems are able to function crucially depends on the sampling gas treatment and the correct heating along the measuring gas route in accordance with the applicable standards and regulations. As the legal regulations become stricter and measurement technology improves even further, the requirements in this sector will increase correspondingly. Therefore, the heating within an analytical system represents a major element of every facility, and this is where Winkler, as a specialist, can always offer the perfect solution.

Rely on our experience and you will be convinced of our products and services!

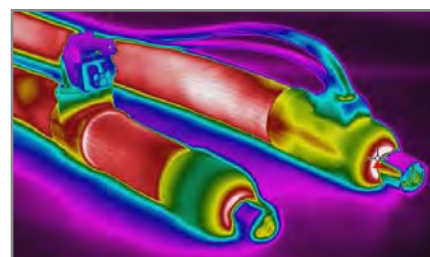
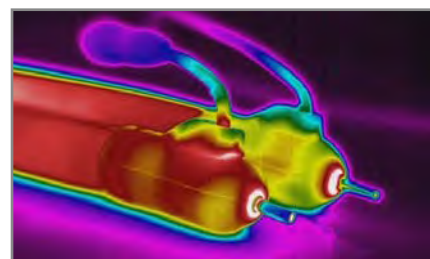

Winkler service

Your direct contact to Winkler :

Tel. +49-6221-3646-0

Fax +49-6221-3646-40

For all inquiries and orders :

E-Mail : sales@winkler-heidelberg.de

Service is an important part of our cooperation with our customers. Winkler not only supplies reliably functioning products, but also complete solutions from one single source. We see ourselves as service providers to and development partners of our customers. Together with you – and with flexibility and creativity – we will find a solution, even for very complex applications.

As a system supplier to manufacturers of high-standard analytical devices and systems we are familiar with the requirements in practice and the application conditions. Often it is certain details that will make the product ideally suited to a particular task.

Make use of our know-how to stay ahead!

In addition to the options already listed, all the products in this catalogue can be individually adapted to your specific projects. In other words, we can offer you a solution that is exactly tailored to the requirements of your application. This approach is technically more elegant, and in the long run it will normally also prove to be more economic.

Don't hesitate and get in touch with our specialists – they'll be happy to advise you!

Winkler quality

The technical experience and high level of quality assurance are reflected in all Winkler products so that our customers can rely on tested and proven products for their applications.

Our heating systems are characterized by an even distribution of heating power and a generously dimensioned heating conductor arrangement. This enables relatively direct and careful heat transfer to the fluid or object to be heated.

We only use high-quality, tried and tested materials and components, and there is no compromise in this respect when it comes to the selection of and cooperation with our suppliers. Our customers are therefore offered excellent and trustworthy products with a long service life, even under heavy load conditions.

Winkler products are 100% routine tested. There are two documented tests already during production, and during the third and final test the analytical measurement lines are again subjected to strict quality inspection. This triple testing procedure ensures a high degree of safety and reliability. And in the long run, these high quality and safety standards are beneficial.

Our quality management system is certified to ISO 9001:2000. Winkler is a certified manufacturer in accordance with Directive 94/9/EC, Appendix VII (ATEX).



Heated lines types WAL + WAH

$T_{Max} = 65^{\circ}C \mid 120^{\circ}C$

Applications

Heated lines for the transport of gas samples in the temperature range up to $120^{\circ}C$.
Ideal for fix installation - especially outdoors - with normal mechanical strain.
Can be cut to any length on site and terminated with termination kit.



Structure

- PTFE-hose, unheated overlapping 500 mm on both ends (see picture).
Options for basic hoses and fittings as well as their available nominal diameters [▶Page 14](#).
- Heating with selflimiting heating tape with protective braiding and polyolefin/fluoropolymer-covering. **Available also with ATEX-connections.**
- Flexible insulation structure with multilayer thermal fleece.
- Outer cover with sturdy corrugated hose made of black polyamide (PA 12) and silicon caps.
- Without sensor, no controller necessary.
- Ready to connect with core cable ends.

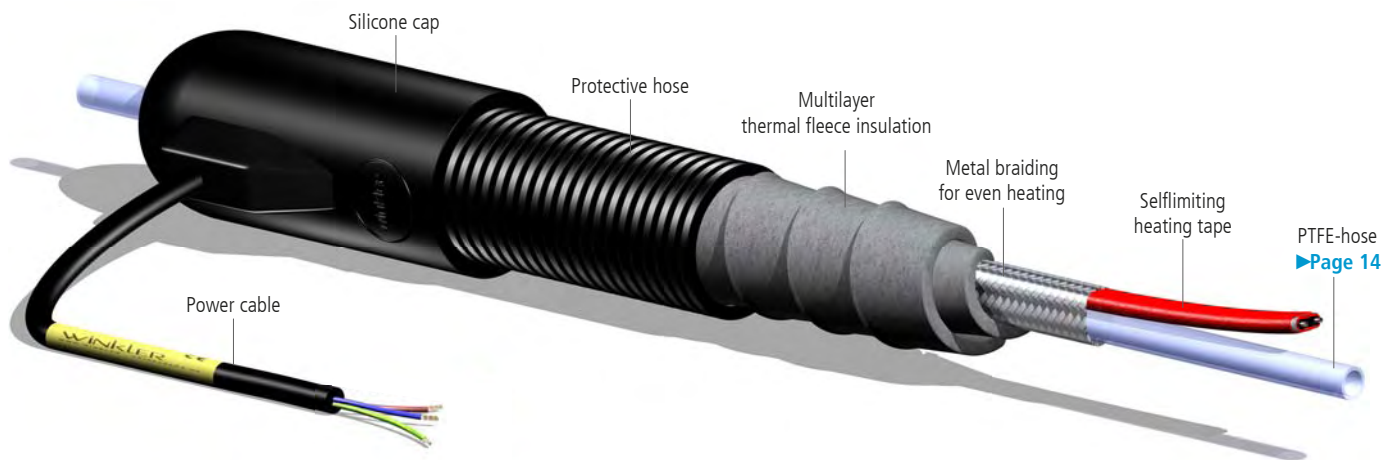

Heated lines type WAP

$T_{Max} = 120^{\circ}C$

Applications

Heated lines for the transport of gas samples in the temperature range up to $120^{\circ}C$.
Ideal for fix installation - especially outdoors - with normal mechanical strain.
Can be cut to any length on site every 60 cm (to insure continuous heating) and terminated with termination kit.

Structure

- PTFE-hose, unheated overlapping 500 mm on both ends (see picture).
Options for basic hoses and fittings as well as their available nominal diameters [▶Page 14](#).
- Heating with parallel heating tape with protective braiding.
- Flexible insulation structure with multilayer thermal fleece.
- Outer cover with sturdy corrugated hose made of black polyamide (PA 12) and silicon caps.
- Built-in temperature sensor [▶Page 16](#) for the operation with a controller.
- Ready to connect with core cable ends.

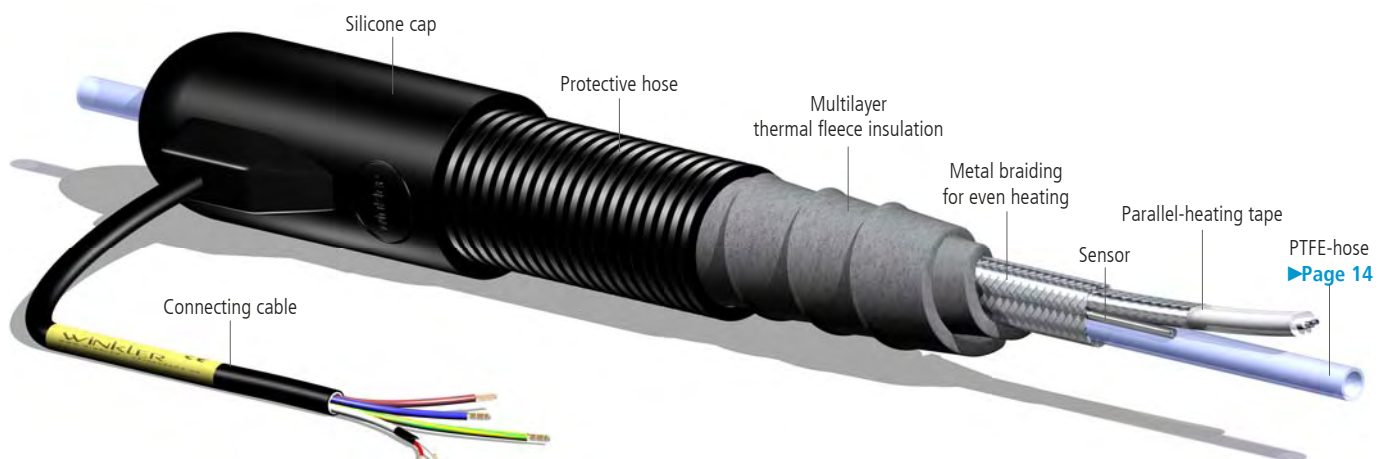

Technical data types WAL, WAH + WAP

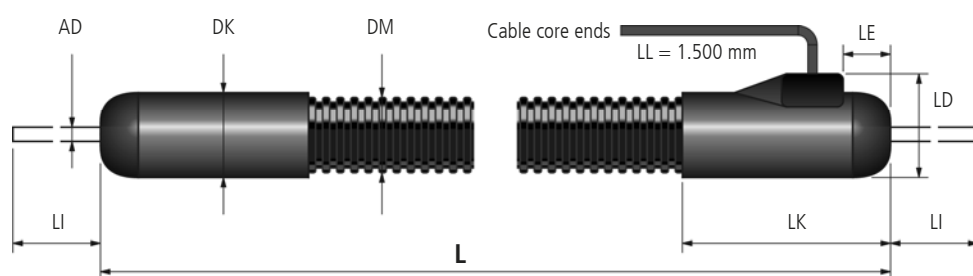

L : Total length of the heated line

AD : Outer diameter of the inner line

DK : Outside diameter of cap

DM : Outside diameter of outer cover

LI : Overlap of inner line

LK : Length of cap

LD : Height of cap with cable outlet

LE : Recess of cable outlet

LL : Length of connecting cable

Dimensions and bend radiuses (Tolerances of length $\pm 2\%$, tolerances of diameter $\pm 5\%$)

ND	2	4	6	8	10
AD	4 mm	6 mm	8 mm	10 mm	12 mm
DK	48 mm				
DM	42,5 mm				
LI	500 mm				
LK	105 mm				
LD	62 mm				
LE	35 mm				
Min. bend radius	200 mm				300 mm

Technical data for 230 VAC (Tolerances of power $\pm 10\%$, T_U : ambient temperatures)

Type	WALW210..	WALW215..	WALW226..	WAHW225..	WAHW245..	WAHW260..	WAPW240..
Power at $T_U = +10^\circ\text{C}$	10 W/m	15 W/m	26 W/m	25 W/m	45 W/m	60 W/m	40 W/m
Temperature maintained at $T_U = +20^\circ\text{C}$	30 - 40°C	35 - 45°C	40 - 50°C	70 - 80°C	90 - 100°C	110 - 120°C	120°C
Temperature maintained at $T_U = -20^\circ\text{C}$	15 - 25°C	20 - 30°C	30 - 40°C	50 - 60°C	80 - 90°C	100 - 110°C	110 - 120°C
 Temperature class (for Ex-Versions)	T6			T3			—
Max. oper. temperature at Power ON	65°C			120°C			120°C
Max. oper. temperature at Power OFF	85°C			190°C			180°C
Admissible ambient temperatures	-20°C / +40°C						
Max. lengths manufactured	78 m			78 m			100 m
Max. length of circuit $T_U = -20^\circ\text{C}$ (16A fuse)	145 m	95 m	59 m	102 m	61 m	45 m	100 m
Max. length of circuit $T_U = -20^\circ\text{C}$ (20A fuse)	183 m	125 m	77 m	128 m	77 m	55 m	100 m

ATEX heated lines and heated hoses type WEX

$T_{Max} = 200\text{ }^{\circ}\text{C}$

Applications

Heated lines and hoses for the transport of fluids in the temperature range up to **200°C** for applications in potentially explosive atmospheres classified zone 1 and 2 areas. Not suitable for zone 0 areas.

Structure

- PTFE basic hose with stainless steel braiding and fittings made of stainless steel 1.4305 (other fittings and materials upon request). Available nominal diameters : 4, 6, 8, 10 and 13 mm. Total length: depending on nominal diameter up to max. 48 m.
- Heating with PTFE-insulated heating wire with protective braiding.
Heating wire and cold ends are manufactured with a special moulded connection technique.
- Flexible insulating structure with multilayer thermal fleece.
- Outer cover with antistatic corrugated hose made of black polyamide (PA12) and antistatic silicon caps.
- Two built in temperature sensors type ATEX Pt 100 for control and limitation of the temperature. Sensor position: 300 mm from the electrical connection side (other sensor positions upon request).
- Operation solely with controller and limiter.
- Power cable: 1,5 m silicon cable. Sensor cable: 1,5 m (other cable lengths upon request) PTFE insulated wires in antistatic corrugated hose made of black polyamide (PA12).
- Ready to connect with core cable ends.

Benefits

- Complete system, ready to connect, tested and certified according to ATEX.
- EC-type examination certificate Nr. EX5 07 10 29587 004**
The EC-type examination certificate certifies the conformity with relevant regulations, according to Annex III of council directive N° 94/9/EC for equipment and protective systems intended for the use in potentially explosive atmospheres (ATEX).
- Very flexible → easy installation.

Marking

- CE 0123 Ex II 2G EEx e ma IIC T3
- CE 0123 Conformity symbol with notified body's identification number (0123 = TÜV Süd)
- Ex Explosion safety symbol for electric equipment
- II Explosion safety symbol for class II
- 2G Equipment category
- EEx Symbol mark for the use of standard series DIN EN 60079-0 gases/fumes
- e Ignition protection type improved safety according to DIN EN 60079-7
- ma Ignition protection type encapsulation according to DIN EN 60079-18
- IIC Explosion group IIC hydrogen
- T3 Class of surface temperatures up to 200 °C



Temperature control and limitation



The respective operating and limiting temperatures of the ATEX heated lines and hoses must always be monitored with the appropriate equipment. Regulations prescribe temperature controllers and limiters (or combinations of both) with intrinsically safe sensor inputs according to ATEX.



Complete digital solution for the control and limitation of temperatures in explosive areas in one unit:
WRWODEPU-230ZE000
Marking: Ex II 2G EEx m e ib [ib] IIC T4
230 VAC (50-60 Hz); max. 25 A; -20 °C up to +40 °C
Aluminium box IP65; LxWxH : 260x200x135 mm



Components for the control outside explosive areas:
2 Controllers **WRH00141-230XW000**
1 Solid state relay (P>500 W) **WRZ00226-230XX025**
1 Contactor (P>1.800 W) **WRZ00224-230XX020**
2 Power supply 24V **WRZ0MK82-230XX024**
2 Measurement transducer **WRZ0MK32-024XT000**

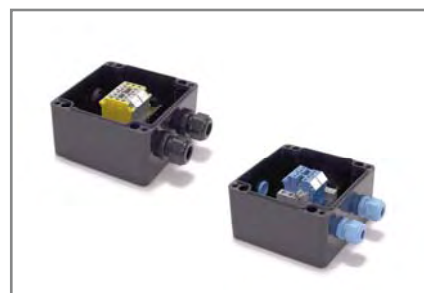

Connection boxes for the connection of cables within explosive areas:
Connection box EExe (Power) **WEZ00188**
Connection box EExi (Sensors) **WEZ00189**

Technical data

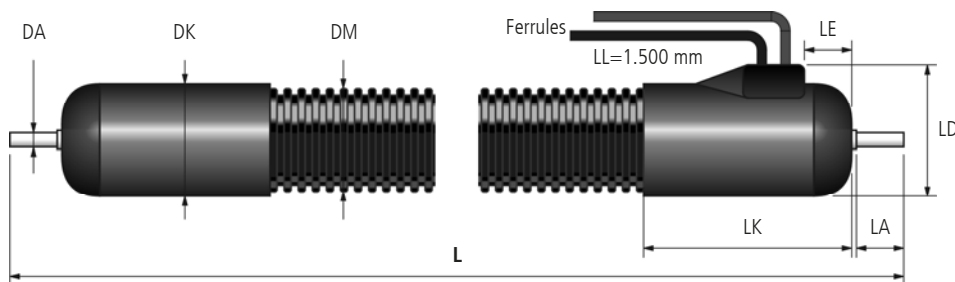

- L : Total length of the heated line
- DA : Outside diameter of fitting
- DK : Outside diameter of cap
- DM : Outside diameter of outer cover
- LA : Length of fitting
- LK : Length of cap
- LD : Height of cap with cable outlet
- LE : Recess of cable outlet

Dimensions and rated power (Tolerances: lengths $\pm 2\%$, diameters $\pm 5\%$)

ND	4	6	8	10	13
DA	6 mm	8 mm	10 mm	12 mm	15 mm
DK	64 mm				
DM	54 mm				
LA	25 mm			26 mm	28 mm
LK	110 mm				
LD	80 mm				
LE	35 mm				
Rated power	100 W/m			125 W/m	
Total max. length	48 m			37 m	
Rated max. pressure*	200 bar	180 bar	160 bar	120 bar	100 bar

Technical data

- Operating temperature : max. 200 °C
- Ambient temperature : -20 °C up to +40 °C
- Operating voltage : 230 VAC (50 Hz)
- Rated power : 30 W – 4.800 W
- Power tolerances : $\pm 10\%$
- Protection class : I
- Min. bend radius : 300 mm

* at 200 °C

Certificates

ZERTIFIKAT ◆ CERTIFICATE ◆ 認証証書 ◆ CERTIFICADO ◆ CERTIFICAT



Product Service

EC-Type Examination Certificate

No. EX5 07 10 29587 004

Holder of Certificate: Winkler GmbH
Wärmetechnik
Englerstraße 24
69126 Heidelberg
GERMANY

Product: Heizgeräte-elektrisch
heated hoses

Model(s):  WEXR020G-230ZEXXX - YYYY
II 2G EEx e ma IIC T3
XXX = nominal diameter of basic hose (mm)
YYYY = length of heated hose (cm)
.... = 0000 to 9999
internal code for sensor position
and kind of faucet

Parameters:

marking:	II 2G EEx e ma IIC T3
rated voltage:	230 V
rated frequency:	50Hz
rated power:	30W - 4800W
type of protection:	I

This EC Type Examination Certificate is issued according to Annex III of Council Directive No. 94/9/EC for Equipment and protective systems intended for use in potentially explosive atmospheres (ATEX). It confirms that the listed product meets the provisions of the Directive. The certificate refers only to the sample submitted to TÜV SÜD Product Service GmbH for testing and certification and on its technical documentation. See also notes overleaf.

Test report no.: 70101735

Date, 2007-11-13





TÜV SÜD Product Service GmbH is a Notified Body in accordance with Council Directive 94/9/EC for equipment and protective systems intended for use in potentially explosive atmospheres with the identification number 0123.

Page 1 of 1

TÜV SÜD Product Service GmbH · Zertifizierstelle · Rüdigerstrasse 65 · 80339 München · Germany

ZERTIFIKAT ◆ CERTIFICATE ◆ 認証証書 ◆ CERTIFICADO ◆ CERTIFICAT



Product Service

EC-Certificate

No. EX3 07 10 29587 005

Holder of Certificate: Winkler GmbH
Wärmetechnik
Englerstraße 24
69126 Heidelberg
GERMANY

Facility(ies): Winkler GmbH Wärmetechnik
Englerstraße 24, 69126 Heidelberg, GERMANY

Scope of Certificate:  heated hoses, model combination:
WEXR020G-230ZEXXX - YYYY
XXX = nominal diameter of basic hose
YYYY = length of heated hose
.... = 0000 to 9999
internal code for sensor position
and kind of faucet

The certification body of TÜV SÜD Product Service GmbH certifies that the certificate holder maintains a quality system which fulfils the requirements of Annex VII of Council Directive No. 94/9/EC for Equipment and protective systems intended for use in potentially explosive atmospheres (ATEX). Validity of this EC-Certificate requires periodical surveillance. See also notes overleaf.

Report No.: 70101735

Valid until: 2009-05-31

Date, 2007-11-19





TÜV SÜD Product Service GmbH is a Notified Body in accordance with Council Directive 94/9/EC for equipment and protective systems intended for use in potentially explosive atmospheres with the identification number 0123.

Page 1 of 1

TÜV SÜD Product Service GmbH · Zertifizierstelle · Rüdigerstrasse 65 · 80339 München · Germany

Heated lines types WAKG + WAKS

$T_{Max} = 100^{\circ}C \mid 200^{\circ}C \mid 250^{\circ}C$

$T_{Max} = 300^{\circ}C \mid 400^{\circ}C^*$

* with stainless steel tube or corrugated hose

Applications

Heated lines for the transport of gas samples in the temperature range up to **250°C**. Well suited for fix installation and mobile use indoors with normal mechanical strain. Versions for high temperatures up to **400°C**.

Structure

- PTFE basic hose with stainless steel braiding and tube ends made of stainless steel 1.4305. Options for basic hoses and fittings as well as their available nominal diameters [▶Page 14](#).
- Heating with PTFE ($T_{Max} < 250^{\circ}C$) or glass silk ($T_{Max} > 250^{\circ}C$) insulated heating cable with protective braiding.
- Soft and extremely flexible insulation structure with glass silk braiding ($T_{Max} > 250^{\circ}C$) and silicon foam. Standard-insulation structure approx. 40 mm (up to ND 16) and approx. 60 mm (from ND 20). Options underneath.
- Outer cover with protective braiding in different versions (WAKG) or silicon skin (WAKS) and silicon caps.
- Built-in temperature sensor [▶Page 16](#) for the operation with a controller.
- Ready to connect with plug.

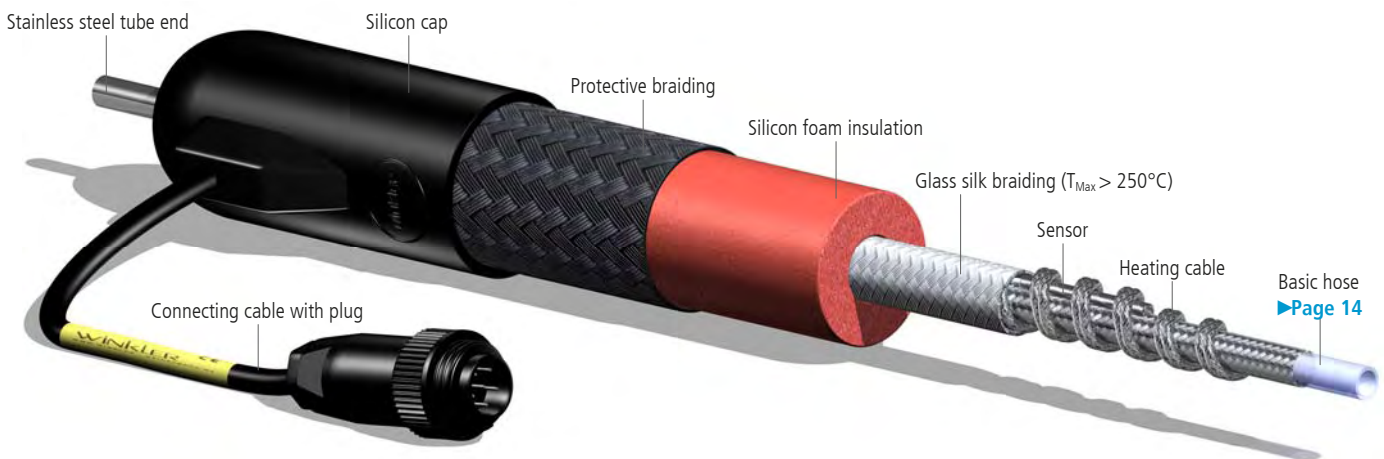

Options of protective braidings for the outer cover of type WAKG



Code G0	Black polyamide braiding. Use for standard applications. Available up to ND 32
G1	Red polyamide braiding (up to ND 16)
G2	Orange polyamide braiding (up to ND 16)
G3	Blue polyamide braiding (up to ND 16)
G4	Grey polyamide braiding (up to ND 16)

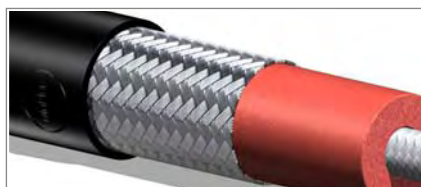

Code G8	Galvanised steel braiding. Very robust. Use for higher strain. Available up to ND 32
----------------	---

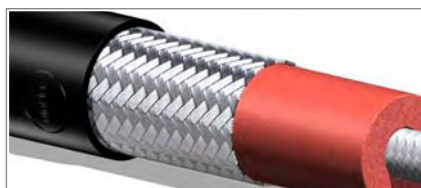

Code G9	Stainless steel braiding. Best performance. Ideal for a long-lasting perfect look. Available up to ND 32
----------------	---

Outer covers for type WAKS

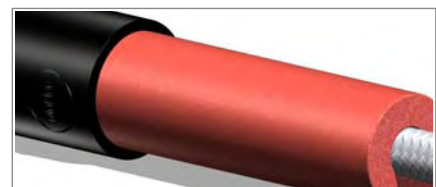

Code S0	Red silicon foam. Light and very flexible. Use inside cabinets. Available up to ND 32
----------------	--



Code S1	Black silicon skin. Washable. Combines flexibility and durability. Available up to ND 10 and lengths up to 20 m
----------------	---

Options of insulation structures for types WAKG and WAKS

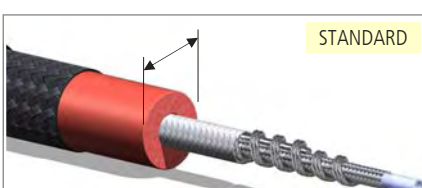

IG40 IS40	Insulation structure approx. 40 mm. IG40 standard up to ND 16 IS40 available up to ND 10
----------------------------	--

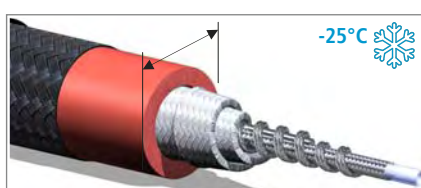

Option IG60	Insulation structure approx. 60 mm. Use for instance in climate chambers. Available up to ND 16 (G0, G8 and G9)
--------------------	--

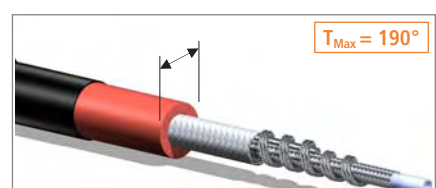

Option IS30	Insulation structure approx. 30 mm. Ideal for cabinets + mobile use. Available for ND 4 and ND 6 (S1)
--------------------	---

Technical data types WAKG and WAKS

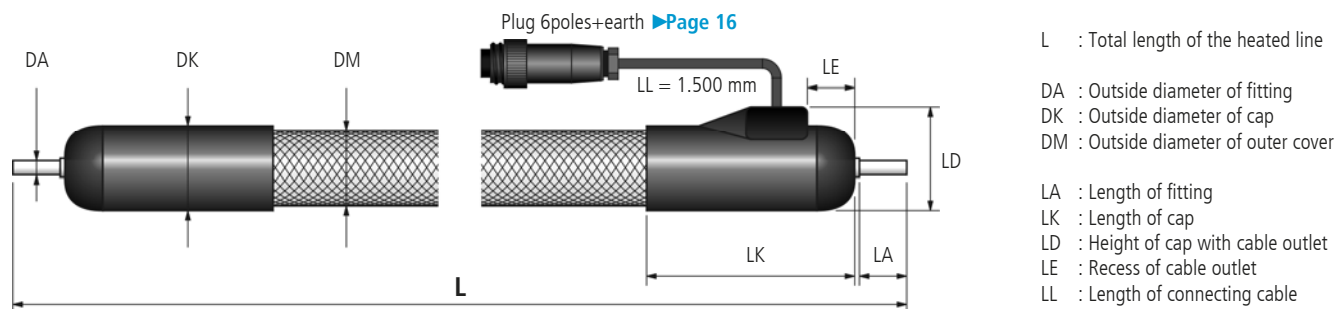

Dimensions and bend radiuses (Tolerances of length $\pm 2\%$, tolerances of diameter $\pm 5\%$)

ND	2	4	6	8	10	13 (12*)	16 (15*)	20	25	32
DA	4 mm	6 mm	8 mm	10 mm	12 mm	15 mm	18 mm	22 mm	28 mm	35 mm
DK	48 mm			52 mm						
DM	42 mm			46 mm						
LA	25 mm				26 mm	28 mm	32 mm	32 mm	34 mm	41 mm
LK	110 mm			105 mm			100 mm			
LD	64 mm									
LE	35 mm									
Min. bend radius	160 mm				250 mm			450 mm	500 mm	600 mm

*For heated lines with corrugated stainless steel hose

Maximum operating temperatures and power (Tolerances of power $\pm 10\%$, ambient temperatures -20°C up to $+40^{\circ}\text{C}$)

T_{Max}	ND	2	4	6	8	10	13	16	20	25	32
100°C	fix	—	100 W/m			125 W/m		150 W/m	180 W/m	240 W/m	300 W/m
	exchang.	100 W/m		125 W/m		150 W/m	—				
200°C	fix	—	100 W/m			125 W/m		150 W/m	180 W/m	240 W/m	300 W/m
	exchang.	100 W/m		125 W/m		150 W/m	—				
250°C	fix	—	125 W/m			150 W/m		240 W/m		400 W/m	
	exchang.	125 W/m		150 W/m		180 W/m	—				
300°C	fix	—	150 W/m		180 W/m	220 W/m	260 W/m	300 W/m	—		
400°C	fix	—	200 W/m		225 W/m	250 W/m	300 W/m	400 W/m	—		

Maximum lengths for operating voltages of 230 VAC and 115 VAC with one heating circuit (Tolerance of lengths $\pm 2\%$)

T_{Max}	ND	2	4	6	8	10	13	16	20	25	32
100°C	230 V	52 m			41 m		34 m	28 m	21 m	17 m	
	115 V	25 m			20 m		17 m	14 m	10 m	8 m	
200°C	230 V	52 m			41 m		34 m	28 m	21 m	17 m	
	115 V	25 m			20 m		17 m	14 m	10 m	8 m	
250°C	230 V	41 m			34 m		21 m		17 m	12 m	
	115 V	20 m			17 m		10 m		8 m	6 m	
300°C	230 V	—	34 m		28 m	23 m	20 m	17 m	—		
	115 V	—	17 m		14 m	11 m	10 m	8 m	—		
400°C	230 V	—	26 m		23 m	20 m	17 m	13 m	—		
	115 V	—	13 m		11 m	10 m	8 m	6 m	—		

Heated lines type WAKW

$T_{Max} = 100^{\circ}C \mid 200^{\circ}C$

Applications

Heated lines for the transport of gas samples in the temperature range up to **200°C**.
Very well suited for fix installation - even outdoors - and the mobile use with higher mechanical strain.

Structure

- PTFE basic hose with stainless steel braiding and tube ends made of stainless steel 1.4305.
Options for basic hoses and fittings as well as their available nominal diameters ▶Page 14.
- Heating with PTFE insulated heating cable with protective braiding.
- Flexible insulating structure with multilayer thermal fleece.
- Standard insulation structure approx. 40 mm (up to ND 13) and approx. 50 mm (ND 16). Options underneath.
- Outer cover with sturdy protective hoses in different versions and silicon caps.
- Built-in temperature sensor ▶Page 16 for the operation with a controller.
- Ready to connect with plug.

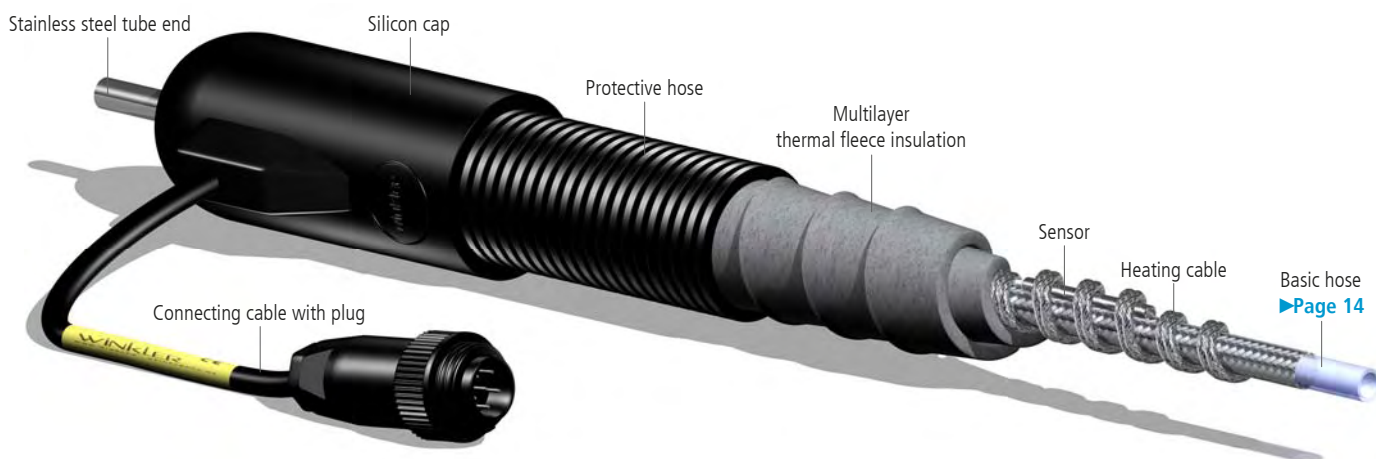

Options of protective hoses for the outer cover of type WAKW

STANDARD

Code W2	Black polyamide (PA) corrugated hose Use for standard applications. Available up to ND 16
Code W3	Black TPE corrugated hose. Mobile use. Not for permanent outdoor use. Available up to ND 13

Only indoor use !

Code W8	Galvanised steel spiral hose. Trittfest. Use for höhere Belastungen Available up to ND 13
----------------	--

Code W7	Spiralschlauch PUR black Use for Sonderanwendungen upon request Available up to ND 25
----------------	--

Nur for Innen !

Code W9	Spiralschlauch stainless steel. Trittfest. Ideal for eine dauerhaft perfekte Optik Available up to ND 13
----------------	---

Options of insulation structures for type WAKW

STANDARD

IW40	Insulation structure approx. 40 mm. Use for standard applications. Available up to ND 16
-------------	---

-25°C ❄️

Option IW50 (W2)	Insulation structure approx. 50 mm. Use for instance in climate chambers. Available up to ND 16
-------------------------	--

$T_{Max} = 180^{\circ}$

Option IW30 (W3)	Insulation structure approx. 30 mm. Ideal for mobile use. Available for ND 4
-------------------------	---

Technical data type WAKW

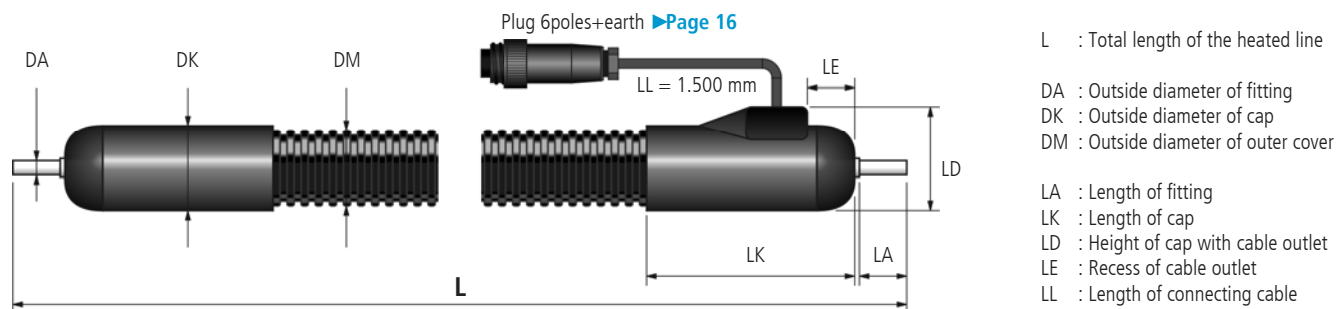

Dimensions and bend radiuses (Tolerances of length $\pm 2\%$, tolerances of diameter $\pm 5\%$)

ND	2	4	6	8	10	13	16
DA	4 mm	6 mm	8 mm	10 mm	12 mm	15 mm	18 mm
DK	48 mm						
DM	42,5 mm						
LA	25 mm				26 mm	28 mm	32 mm
LK	105 mm						
LD	62 mm						
LE	25 mm						
Min. bend radius	200 mm				300 mm		

Maximum operating temperatures and power (Tolerances of power $\pm 10\%$, ambient temperatures -20°C up to $+40^\circ\text{C}$)

T_{Max}	ND	2	4	6	8	10	13	16
100°C	fix	–	100 W/m			125 W/m		150 W/m
	exchangeable	100 W/m		125 W/m		150 W/m	–	
200°C	fix	–	100 W/m			125 W/m		150 W/m
	exchangeable	100 W/m		125 W/m		150 W/m	–	

Maximum lengths for operating voltages of 230 VAC and 115 VAC with one heating circuit (Tolerance of lengths $\pm 2\%$)

T_{Max}	ND	2	4	6	8	10	13	16
100°C	230 V	52 m				41 m		34 m
	115 V	25 m				20 m		17 m
200°C	230 V	52 m				41 m		34 m
	115 V	25 m				20 m		17 m

Heated lines with filter type **WAF**

$T_{Max} = 200^{\circ}C$

Applications

Heated lines for the transport of gas samples charged with particles in the temperature range up to **200°C**.
Ideal for mobile use with higher mechanical strain.

Structure

- PTFE basic hose **ND 4 or 6 mm** with stainless steel braiding and tube ends made of stainless steel 1.4305.
Filter housing in stainless steel with removable filter element.
Quick replacement and optimum cleanability of the filter element.
- Heating with PTFE insulated heating cable with protective braiding.
- Flexible insulating structure with multilayer thermal fleece and sturdy protective hoses in different versions or with flexible silicon foam and protective braiding in different versions. Options underneath.
- Built-in temperature sensor [▶Page 16](#) for the operation with a controller.
- Ready to connect with plug.

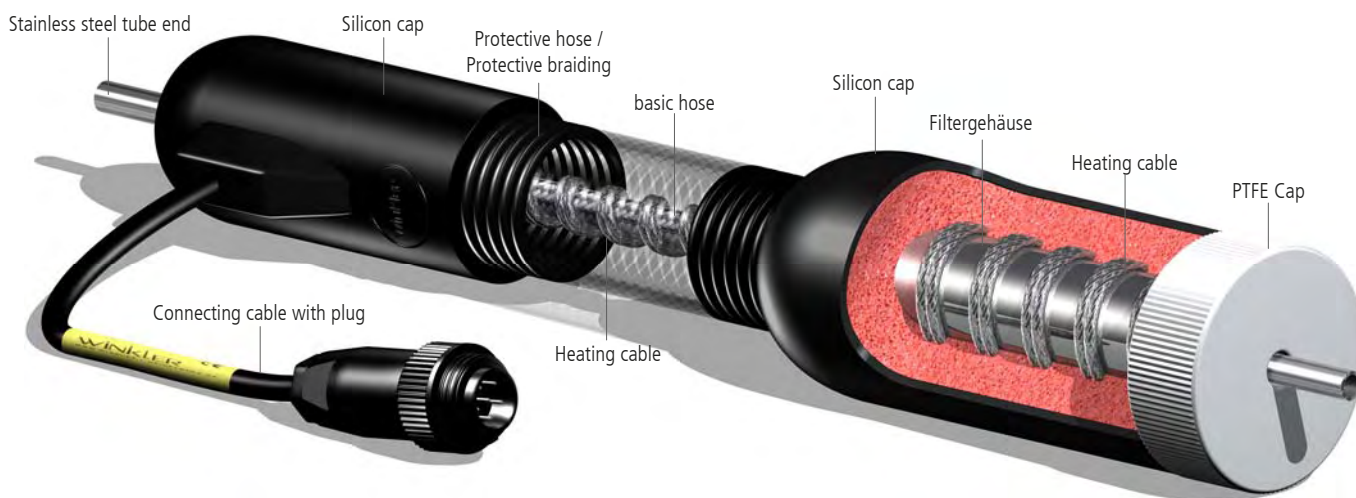

Options for the outer cover of type **WAF** (Other options [▶Page 8+10](#))



Code W2 Black polyamide (PA) corrugated hose
Use for standard applications.



Code G0 Black polyamide braiding.
Use for standard applications.

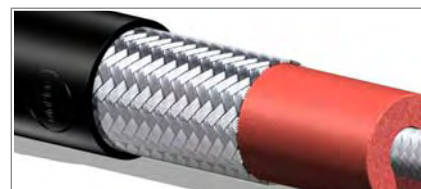

Code G9 Stainless steel braiding. Best performance.
Ideal for a long-lasting perfect look.

Technical data type **WAF** (Tolerances of length $\pm 2\%$, tolerances of diameter $\pm 5\%$)

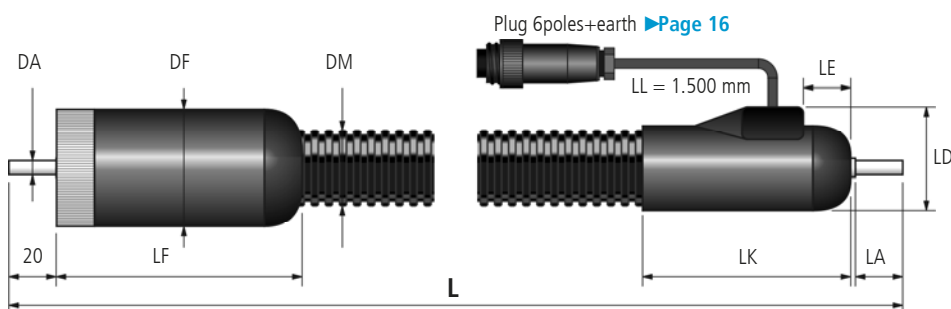

L : Total length of the heated line

DA : Outside diameter of fitting
DF : Diameter of filter housing
DM : Outside diameter of outer cover

LF : Length of filter housing incl. cap
LA : Length of fitting
LK : Length of cap
LD : Height of cap with cable outlet
LE : Recess of cable outlet
LL : Length of connecting cable

ND	DA	DF	DM	LF	LA	LK	LD	LE	Min. bend radius
4	6 mm	65 mm	43 mm	132 mm	25 mm	105 mm	62 mm	35 mm	200 mm
6	8 mm	65 mm	43 mm	132 mm	25 mm	105 mm	62 mm	35 mm	200 mm

Heated lines type WAM

$T_{Max} = 200^{\circ}C \mid 250^{\circ}C$

Applications

Heated lines for the channelling of exhaust gases and for gas sampling directly at the exhaust pipe in the temperature range up to **250°C**. Available in nominal diameters from 40 mm to 150 mm [▶Page 14](#)

Structure

- Stainless steel corrugated hose with stainless steel protective braiding and stainless steel tube ends.
- Heating with PTFE insulated heating cable with protective braiding.
- Flexible insulation structure with multilayer thermal fleece ($T_{Max} = 200^{\circ}C$) or glass silk braiding ($T_{Max} > 250^{\circ}C$) and silicon foam.
- Outer cover with rugged stainless steel protective braiding and silicon or PVC caps.
- Built-in temperature sensor [▶Page 16](#) for the operation with a controller.
- Ready to connect with plug.

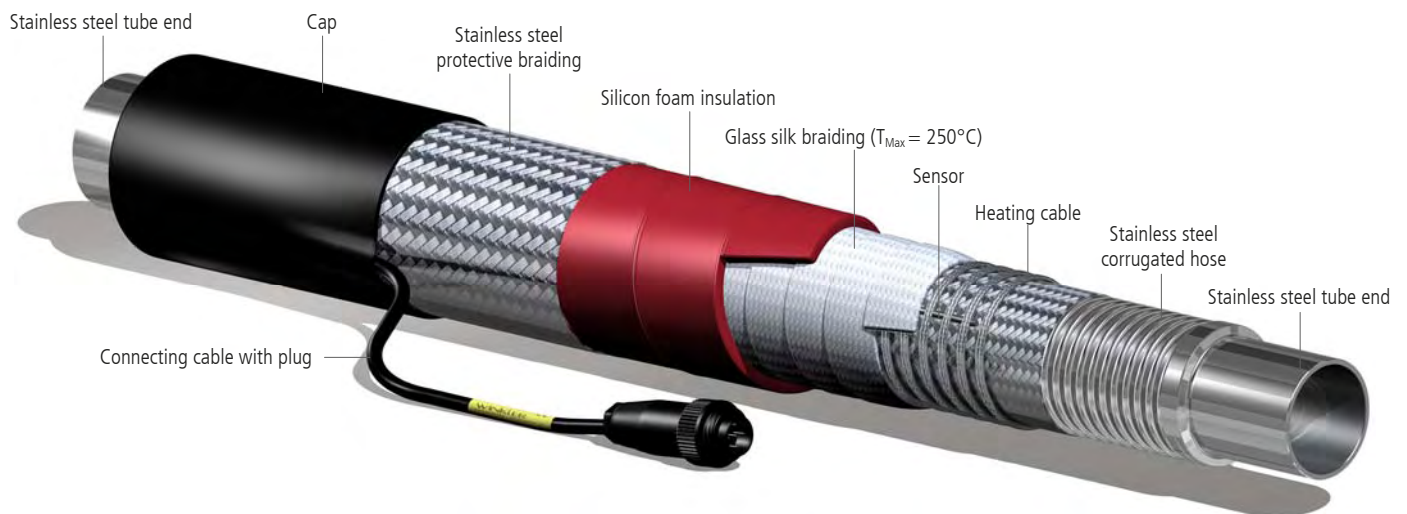

Technical data type WAM (Tolerances of length $\pm 2\%$, tolerances of diameter $\pm 5\%$)

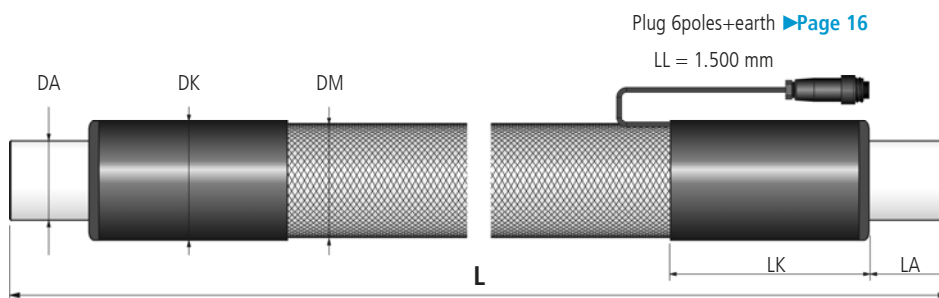

- L : Total length of the heated line
- DA : Outside diameter of fitting
- DK : Outside diameter of cap
- DM : Outside diameter of outer cover
- LA : Length of fitting
- LK : Length of cap
- LL : Length of connecting cable

ND	DA	DK	DM	LA	LK	Min. bend radius
80	80 mm	120 mm	110 mm	80 mm	180 mm	800 mm

Standard basic hoses and fittings

Example: type 3 → WAKG0203-230XP006-1500STND

Available basic hoses and fittings for heated lines of the types listed. Depending on design, basic hoses with PTFE hose can be employed for fluid temperatures up to 250°C. Heated lines with stainless steel pipes and corrugated stainless steel hoses are designed for fluid temperatures up to 400°C, depending on the type of insulation.

Higher temperatures and special solutions upon enquiry.

		Types of heated lines					
		WAL/H WAP	WEX	WAKG	WAKS	WAKW	WAF WAM
		▶ Page 4	▶ Page 6	▶ Page 8	▶ Page 8	▶ Page 10	Page 12,13
	Type 0 PTFE hose (overlapping 500 mm on both ends)	ND 2 ND 4 ND 6 ND 8 ND 10		Auf Anfrage	Auf Anfrage	Auf Anfrage	
T_{Max} = 250°							
	Type 1 Exchangeable PTFE hose in hose (overlapping 500 mm on both ends)	ND 2 ND 4 ND 6		Auf Anfrage	Auf Anfrage	Auf Anfrage	
T_{Max} = 250°							
	Type 3 PTFE basic hose + stainless steel tube ends	ND 4 ND 6 ND 8 ND 10	ND 4 ND 6 ND 8 ND 10 ND 13	ND 4 ND 6 ND 8 ND 10 ND 13 ND 16,20 ND 25,32	ND 4 ND 6 ND 8 ND 10	ND 4 ND 6 ND 8 ND 10 ND 13 ND 16	WAF ND 4 ND 6
T_{Max} = 250°							
	Type 4 PTFE carrier hose with exchangeable PTFE hose (overlapping 500 mm on both ends) + stainless steel tube ends	ND 4 ND 6		ND 4 ND 6 ND 8	ND 4 ND 6 ND 8	ND 4 ND 6 ND 8	
T_{Max} = 250°							
	Type 5 Stainless steel tube (overlapping 50 mm on both ends)	ND 4 ND 6		ND 4 ND 6 Larger ND upon request	ND 4 ND 6 Larger ND upon request	ND 4 ND 6 Larger ND upon request	
T_{Max} = 800°							
	Type 6 PTFE carrier hose with exchangeable PTFE hose (overlapping 500 mm on both ends)	ND 2 ND 4 ND 6		ND 2 ND 4 ND 6 ND 8	ND 2 ND 4 ND 6 ND 8	ND 2 ND 4 ND 6 ND 8	
T_{Max} = 250°							
	Type 7 Corrugated stainless steel hose + stainless steel studs			ND 6 ND 8 ND 10 ND 12 ND 15	ND 6 ND 8 ND 10	ND 6 ND 8 ND 10 ND 12 ND 15	WAM ND 40 ND 50 ND 65 ND 80 ND 100 ND 125 ND 150
T_{Max} = 600°							
	Type 8 PTFE carrier hose with exchangeable PTFE hose + exchangeable stainless steel tube ends			ND 2 ND 4 ND 6 ND 8	ND 2 ND 4 ND 6 ND 8	ND 2 ND 4 ND 6 ND 8	
T_{Max} = 250°							
	Type 9 PTFE carrier hose with exchangeable PTFE hose + stainless steel ferrule fittings			ND 4 ND 6 ND 8	ND 4 ND 6 ND 8	ND 4 ND 6 ND 8	
T_{Max} = 250°							

Nominal diameters ND

Example : ND = 6 mm → WAKG0203-230XP006-1500STND

Important ! The nominal diameter (ND) of a heated line always refers to the inner diameter (ID) in mm of the inner hose or the inner tube.

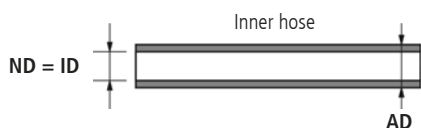

Important ! The nominal diameter is not to be confused with the dimensions of the fitting.



Nominal diameter (mm)		Inner diameter ID	Outer diameter AD
ND	Code	Inner hose	Inner hose
4	004	4 mm	6 mm
6	006	6 mm	8 mm
8	008	8 mm	10 mm
10	010	10 mm	12 mm
13	013	13 mm	15 mm
16	016	16 mm	18 mm

Innenschläuche + Innenrohre



PTFE-hose

Standard in all basic hoses of types 0, 1, 3, 4, 6, 8 and 9.

Resistant to all chemical agents, acids and bases of any concentration. Exception: alkaline metals and fluorine compounds.

For replacement :

ND 4 : Art.-Nr. WAZ02742-004TX006
 ND 6 : Art.-Nr. WAZ02743-006TX008
 ND 8 : Art.-Nr. WAZ02744-008TX010
 ND 10 : Art.-Nr. WAZ02745-010TX012

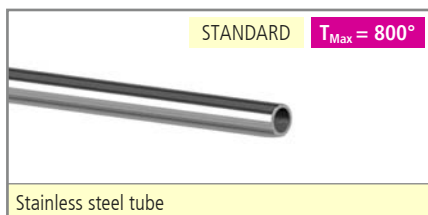

Stainless steel tube 1.4404

Standard in heated lines of type 5
 Available in ND 4 and 6 mm
 Other nominal diameters upon request

For replacement :

ND 4 : Art.-Nr. WAZ02753-004VV006
 ND 6 : Art.-Nr. WAZ02754-006VV008

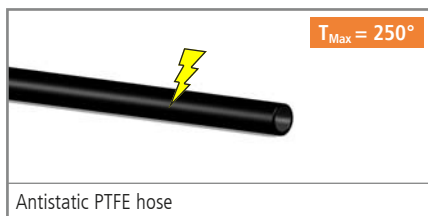

Option antistatic PTFE hose

For all basic hose with exchangeable hoses of types 0, 1, 4, 6, 8 and 9.
 Available in ND 4 - ND 13



Option PFA-hose

For all basic hose with exchangeable hoses of types 0, 1, 4, 6, 8 and 9.
 Available in ND 4

Lengths of heated lines L

Example : L = 15 m → WAKG0203-230XP006-1500STND

Lengths of heated lines

We supply heated lines to the exact length required, ranging from 0,30 m to 78 m.
 As from certain lengths, several heating circuits or three-phase arrangements will be necessary, depending on voltage, temperature and power.

Tolerances : ± 2 %

Pressure or thermal load variations during operation can result in changes in length of up to ± 2 %.

Operating voltages

Standard: 230 VAC-50 Hz

Options: 12 VAC, 24 VAC, 48 VAC, 115 VAC, 200VAC, 400 VAC, 480 VAC
12 VDC, 24 VDC, 48 VDC
Others upon request

Temperature sensors

Standard types of sensors:

Temperature sensor Pt 100 (2 wire)	Code XP
Thermocouple type K (NiCr-Ni)	Code XK
Thermocouple type J (Fe-CuNi)	Code XJ

Options for types of sensors:

Temperature sensor Pt 100 (3 wire)	Code XT
Temperature sensor Pt 100 (4 wire)	Code XQ
Bi-metal temperature controller	Code XB
Temperature fuse	Code XS

Options for multiple sensors and sensor combinations:

Multiple sensors

2 x Pt 100 (2 wire)	Code ZP
3 x Pt 100 (2 wire)	Code DP
2 x thermocouple type K	Code ZK
... etc.	

Sensor combination e.g. Pt100 + thermocouple type K

...	Code PK
...	

Example: 230 V → WAKG0203-230XP006-1500STND

Standard: One heating circuit = one heating zone

Options: Several heating circuits → several heating zones.
3-phase layout possible.

Example: Pt 100 → WAKG0203-230XP006-1500STND

Standard sensor position:

The sensor position is always measured from the electrical connection side.
LS = 300 mm for heated lines with heating cable.
LS = 1.000 mm for heated lines with parallel heating tape.

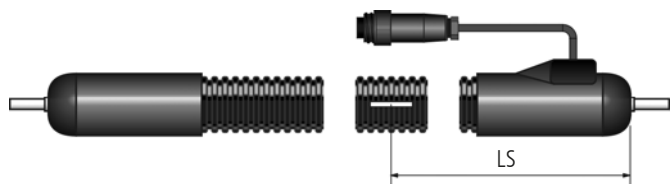

Optional sensor positions:

Please indicate your desired sensor position **LS** in your order.
The correct position of the sensor is particularly important in cases of (partial) installation in switch cabinets, through walls or outdoors.
Please ask our specialists for advice.



Important!

Exposure to wind, as in the case of outdoor installations, can cool down the heated line quite considerably. Under these conditions, the heated line should be laid with appropriate protection, provided with stronger insulation (see options) and/or more power (W/m), while the temperature sensors have to be strategically placed. If the analytical measurement line runs through areas with different ambient temperatures, the internal hose temperature will vary accordingly. This can be prevented by incorporating different heating zones with separate control.

Connecting cables and plugs

Standard:

- Power- and sensor cable together.
- Cable exit sideways according to type 1.
- Length of connecting cable: 1,5 m
- 7-pin round plug (< 10 A), 5-pin round plug (< 20 A)
- Cable ends with ferrules (types WAL, WAH, WAP, WEX)

Options:

- Power and sensor cable routed separately.
- Cable exits according to types 2, 3, 4 or 5
- Other lengths of connecting cable possible from 0,1 m.
- Without plug (cable ends with ferrules)
- Other plugs : You may specify other kinds of plugs required apart from the standard. If the correct type is not known, please send us a sample and the desired pin assignment.

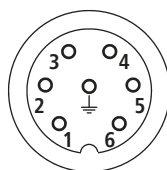

Pin assignment (7-pin round plug)

1 : Power (L)	5 : Sensor (+)
2 : Power (N)	6 : Sensor (-)
3 : free	PE : Earth
4 : free	

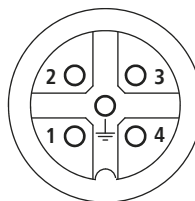

Pin assignment (5-pin round plug)

1 : Power (L)	3 : Sensor (+)
2 : Power (N)	4 : Sensor (-)
	PE : Earth

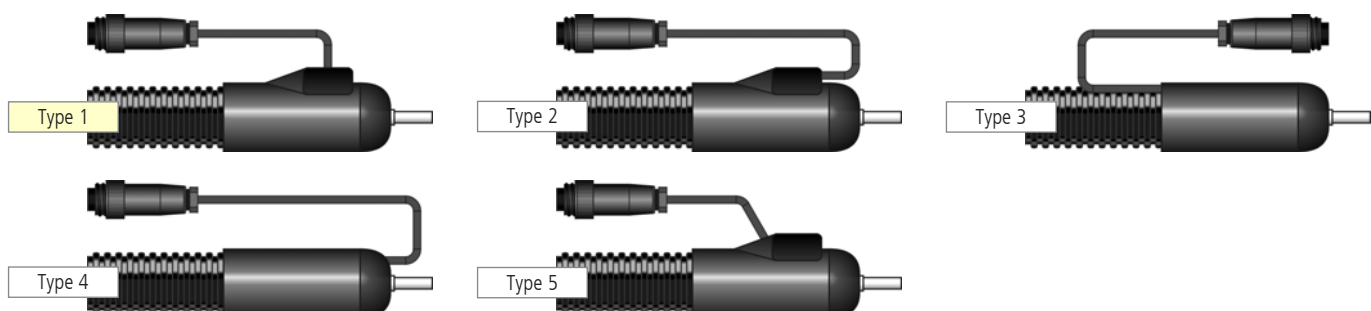

Controllers

The quality of control and monitoring equipment is decisive for maintaining the exact fluid temperature, protecting the service life of the heated line, and ensuring trouble-free operation of your plant.

Winkler controllers are robust, reliable and designed for continuous duty in industrial environments. Thanks to the clear and user-friendly control panels of our devices, even complex control processes can be carried out quickly and accurately. We offer a comprehensive range of high-quality control monitoring equipment optimally adapted to our heated lines. Special controllers can be built upon request.

All devices also available for use with 115 V upon request.



Art.-Nr. **WRH00141-230XW000**

- Compact controller with microprocessor for DIN-Rail installation.
- Switching capacity: 230 V, 8 A, 500 W
- Universal sensor entry for Pt 100 and thermocouples.
- 4-digit LED Display 0...999 °C. 4 LED for status indication.
- Quick and easy configuration through foil keyboard.
- Selectable regulation algorithm with self-tuning.



Art.-Nr. **WRW00110-230XP000** for operation with Pt 100 sensor

Art.-Nr. **WRW00110-230XK000** for operation with thermocouple type K

Art.-Nr. **WRW00110-230XJ000** for operation with thermocouple type J

- Controller with microprocessor ready to use for wall installation.
- Switching capacity: 230 V, 10 A, 2.300 W
- Device with plug ready to use. Connection of the heater through 7-pin round socket.
- 4-digit LED Display 0...999 °C. 2 LED for status indication.
- Quick and easy configuration through foil keyboard.



Art.-Nr. **WRW00120-230XW000**

for use with Pt 100 sensor and thermocouples type K / J (selectable)

- Controller with microprocessor for wall installation.
- Switching capacity: 230 V, 10 A, 2.300 W
- Connection of heater through screw type terminals.
- 4-digit LED Display 0...999 °C. 2 LED for status indication.
- Quick and easy configuration through foil keyboard.



Art.-Nr. **WRW00113-230XP000** for use with Pt 100 sensor

Art.-Nr. **WRW00113-230XK000** for use with thermocouple type K

Art.-Nr. **WRW00113-230XJ000** for use with thermocouple type J

- Controller with microprocessor ready to use with **solid state relay** for wall installation.
- Switching capacity: 230 V, 16 A, 3600 W
- Device with plug ready to use. Connection of the heater through 5-pin round socket.
- 4-digit LED Display 0...999 °C. 2 LED for status indication.
- Quick and easy configuration through foil keyboard. Selectable regulation algorithm.



Art.-Nr. **WRWA6780-230XP000** for use with 2 Pt 100 sensors

Art.-Nr. **WRWA6780-230XK000** for use with 2 thermocouples type K

Art.-Nr. **WRWA6780-230XJ000** for use with 2 thermocouples type J

- Controller and limiter combination with microprocessor ready to use for wall installation.
- Switching capacity: 230 V, 10 A, 2300 W
- Device with plug ready to use. Connection of the heater through 7-pin round socket.
- 4-digit LED Display 0...999 °C. 2 LED for status indication.
- Quick and easy configuration through foil keyboard.

Accessories and spare parts : Plugs, couplings and sockets

Art.-Nr. WZZS0904-2507P10A

Plug 6+PE with cap
250 V, 10 A, IP 65, screw connections, -40 °C / +100°C



Art.-Nr. WZZS0908-2507P10A

Coupling 6+PE with cap
250 V, 10 A, IP 65, screw connections, -40 °C / +100°C



Art.-Nr. WZZS0906-2507P10A

Flange socket 6+PE with cap and screws
250 V, 10 A, IP 65, screw connections, -40 °C / +100°C



Art.-Nr. WZZS0939-4005P20A

Plug 4+PE with cap
400 V, 20 A, IP 65, screw connections, -40 °C / +100°C



Art.-Nr. WZZS0971-4005P20A

Coupling 4+PE with cap
400 V, 20 A, IP 65, screw connections, -40 °C / +100°C



Art.-Nr. WZZS0940-4005P20A

Flange socket 4+PE with cap and screws
400 V, 20 A, IP 65, screw connections, -40 °C / +100°C



Art.-Nr. WZZS0942-4004P16A

Plug 3+PE with cap
400 V, 16 A, IP 65, screw connections, -40 °C / +100°C



Art.-Nr. WZZS0943-4004P16A

Coupling 3+PE with cap
400 V, 16 A, IP 65, screw connections, -40 °C / +100°C







Art.-Nr. WZZS0993-4004P16A

Flange socket 3+PE with cap and screws
400 V, 16 A, IP 65, screw connections, -40 °C / +100°C

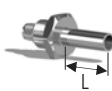

Accessories and spare parts : Exchangeable fittings in stainless steel 1.4305 for basic hoses type 8

	STANDARD L = 25 mm	Hose adapter ND 4 mm Thread M 12 x 1,5 mm - SW 17		Hose adapter ND 6 mm Thread M 14 x 1,5 mm - SW 19		Hose adapter ND 8 mm Thread M 18 x 1,5 mm - SW 22	
		↓ Tube end (ID / AD mm)		↓ Tube end (ID / AD mm)		↓ Tube end (ID / AD mm)	
	L = 50 mm	4 / 6	WAZRSLAM-004VZ006-0025STND	4 / 6	WAZRSLAM-006VZ006-0025STND	6 / 8	WAZRSLAM-008VZ008-0025STND
		6 / 8	WAZRSLAM-004VZ008-0025STND	6 / 8	WAZRSLAM-006VZ008-0025STND	8 / 10	WAZRSLAM-008VZ010-0025STND
				8 / 10	WAZRSLAM-006VZ010-0025STND		
	L = 100 mm	4 / 6	WAZRSLAM-004VZ006-0100STND	4 / 6	WAZRSLAM-006VZ006-0100STND	6 / 8	WAZRSLAM-008VZ008-0100STND
		6 / 8	WAZRSLAM-004VZ008-0100STND	6 / 8	WAZRSLAM-006VZ008-0100STND	8 / 10	WAZRSLAM-008VZ010-0100STND
				8 / 10	WAZRSLAM-006VZ010-0100STND		
	L = 150 mm	4 / 6	WAZRSLAM-004VZ006-0150STND	4 / 6	WAZRSLAM-006VZ006-0150STND	6 / 8	WAZRSLAM-008VZ008-0150STND
		6 / 8	WAZRSLAM-004VZ008-0150STND	6 / 8	WAZRSLAM-006VZ008-0150STND	8 / 10	WAZRSLAM-008VZ010-0150STND
				8 / 10	WAZRSLAM-006VZ010-0150STND		
	L = 200 mm	4 / 6	WAZRSLAM-004VZ006-0200STND	4 / 6	WAZRSLAM-006VZ006-0200STND	6 / 8	WAZRSLAM-008VZ008-0200STND
		6 / 8	WAZRSLAM-004VZ008-0200STND	6 / 8	WAZRSLAM-006VZ008-0200STND	8 / 10	WAZRSLAM-008VZ010-0200STND
				8 / 10	WAZRSLAM-006VZ010-0200STND		

Accessories and spare parts : Silicon caps

- Applications** Covering of line ends, repair of outer covers, strengthening of passages, manufacturing of insulations.
- Technical data** Black, smooth, elastic and extremely tear proof. Wall thickness approx. 3 mm. High chemical resistance. Very low humidity absorption, very good elasticity. Long time temperature stability -60 °C / + 240 °C. Tolerances of dimensions ±10%
- Handling** Cut with a sharp knife. Expand slightly to cover and glue with silicon Art.-Nr. WZZ00629-000ST090.

Art.-Nr. WZK00715-028SB034
Black silicon cap, without cable outlet
ID 28 mm, AD 34 mm, length 100 mm



Art.-Nr. WZK00716-028SB034
Black silicon cap, with cable outlet
ID 28 mm, AD 34 mm, length 100 mm

Art.-Nr. WZK00709-038SB044
Black silicon cap, without cable outlet
ID 38 mm, AD 44 mm, length 110 mm



Art.-Nr. WZK00708-038SB044
Black silicon cap, with cable outlet
ID 38 mm, AD 44 mm, length 110 mm

Art.-Nr. WZK00704-058SB064
Black silicon cap, without cable outlet
ID 58 mm, AD 64 mm, length 110 mm

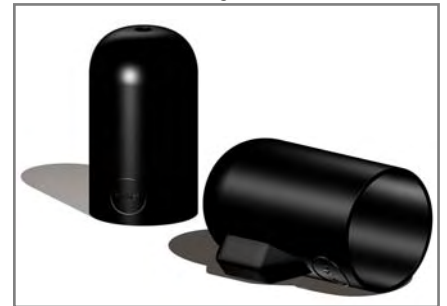

Art.-Nr. WZK00703-058SB064
Black silicon cap, with cable outlet
ID 58 mm, AD 64 mm, length 110 mm

Accessories and spare parts : Silicon foam hoses

- Applications** Insulation of pipes, fittings and passages, mechanical protection of sensitive parts.
- Technical data** Fine pored, closed cell silicon foam hose sold by the meter. Light, elastic, tear proof. High chemical resistance. Very low humidity absorption, very good elasticity. Long time temperature stability -60 °C / + 240 °C. Tolerances of dimensions ±10%
- Handling** Cut to length with a sharp knife. Fix with Velcro tape Art.-Nr. WZZ00622-005HF020.

Art.-Nr. WZI01336-018SR030
Red silicon foam hose
ID 18 mm, AD 30 mm, sold by the meter

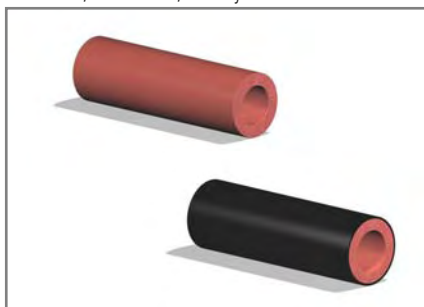

Art.-Nr. WZI01337-018SB032
Silicon foam hose with black silicon skin
ID 18 mm, AD 32 mm, sold by the meter

Art.-Nr. WZI01313-021SR040
Red silicon foam hose
ID = 21 mm, AD = 40 mm, sold by the meter

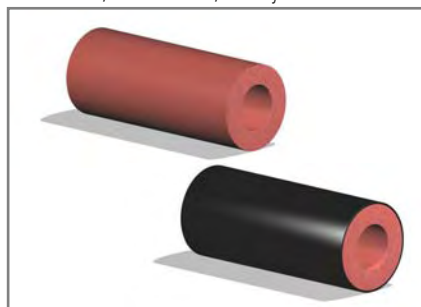

Art.-Nr. WZI01315-021SB042
Silicon foam hose with black silicon skin
ID = 21 mm, AD = 42 mm, sold by the meter

Art.-Nr. WZI01355-030SR040
Red silicon foam hose
ID = 30 mm, AD = 40 mm, sold by the meter

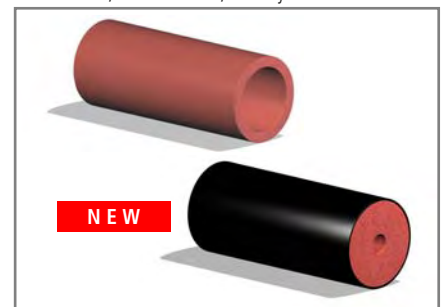

Art.-Nr. WZI03314-008SB042
Silicon foam hose with black silicon skin
ID = 8 mm, AD = 42 mm, sold by the meter

Art.-Nr. WZI01312-040SR060
Red silicon foam hose
ID 40 mm, AD 60 mm, sold by the meter



Art.-Nr. WZZ00622-005HF020
Velcro tape, hooks on front side, fleece on rear side
20 mm wide, 5 mm strong, 5 m reel



Art.-Nr. WZZ00629-000ST090
Transparent silicon glue
90 ml tube incl. nozzle and winding hook



Winkler GmbH is an independent, medium-sized company located in Heidelberg (Germany). For 30 years we have been developing and manufacturing a broad range of electric heating solutions for industry and laboratory applications.

We supply reliable and durable products made of high-quality materials.

We are the right partner for innovative and quick answers to your requirements. Customized solutions and flexible manufacturing are our particular strengths. Our experienced specialists will offer you sound advice and - together with you - develop the heating solution tailored to your application.

Winkler - Your heating solution™



Our headquarter



Heidelberg

Winkler GmbH
Englerstrasse 24
D-69126 Heidelberg
Germany

Tel. +49-6221-3646-0
Fax +49-6221-3646-40
E-Mail sales@winkler.eu

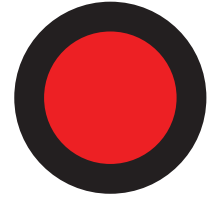

Our product range



Company presetation



ATEX heated lines
& heated hoses



Heated hoses



Silicone heaters &
heating foils



Heating jackets



PILZ® Laboratory
heating mantles

Our representatives

NORTH-GERMANY

Hermann Seidel GmbH, 22149 Hamburg
Tel. +49-40-675085-0
Fax +49-40-675085-85
E-Mail: info@seidel-gmbh.de

EAST-GERMANY

Dr. Stefan Pötschke, 09114 Chemnitz
Tel. +49-371-4144-12
Fax +49-371-4144-29
E-Mail: info@dr-poetschke.de

WEST-GERMANY

Winfried Hunger, 58515 Lüdenscheid
Tel. +49-2351-973003
Fax +49-2351-973005
E-Mail: w.hunger@sensor-data.com

SOUTH-WEST-GERMANY

Willi Kaluza, 76530 Baden-Baden
Tel. +49-7221-25444
Fax +49-7221-26319
E-Mail: kaluza@k-w-industrieservice.de

SOUTH-EAST-GERMANY

Ing.-Büro Voss GmbH, 81829 München
Tel. +49-89-4292-49
Fax +49-89-4292-40
E-Mail: office@voss-gmbh.com

FRANCE

André Weinzaepflen, F-75016 Paris
Tel. +33-1-46041590
Fax +33-1-46041590
E-Mail: commercial@winkler-france.com

BENELUX

KSR H&H Measurement BV, NL-5133 NE Riel
Tel. +31-13-5339688
Fax +31-13-5331962
E-Mail: sales@winkler-benelux.com

AUSTRIA

Ing. Wolfgang Stipanitz, A-4060 Leonding
Tel. +43-732-770177
Fax +43-732-770177-7
E-Mail: sales@winkler-austria.com

DENMARK

Newtronic ApS,
Stensballe Strandvej 181, DK-8700 Horsens
Tel. +45-76-69-70-90
Fax +45-76-27-70-90
Email: sales@winkler-danmark.com